



SIMULATION OPTIMIZATION SYSTEMS
Research Laboratory

**MULTIPLE SPACE MAPPING EM OPTIMIZATION
OF SIGNAL INTEGRITY
IN HIGH-SPEED DIGITAL CIRCUITS**

J.W. Bandler, R.M. Biernacki, S.H. Chen and Q.H. Wang

SOS-98-28-R

September 1998



**MULTIPLE SPACE MAPPING EM OPTIMIZATION
OF SIGNAL INTEGRITY
IN HIGH-SPEED DIGITAL CIRCUITS**

J.W. Bandler, R.M. Biernacki, S.H. Chen and Q.H. Wang

SOS-98-28-R

September 1998

© J.W. Bandler, R.M. Biernacki, S.H. Chen and Q.H. Wang 1998

No part of this document may be copied, translated, transcribed or entered in any form into any machine without written permission. Address enquiries in this regard to Dr. J.W. Bandler. Excerpts may be quoted for scholarly purposes with full acknowledgement of source. This document may not be lent or circulated without this title page and its original cover.

**MULTIPLE SPACE MAPPING EM OPTIMIZATION OF SIGNAL INTEGRITY
IN HIGH-SPEED DIGITAL CIRCUITS**

J.W. Bandler, R.M. Biernacki, S.H. Chen and Q.H. Wang

Simulation Optimization Systems Research Laboratory
Department of Electrical and Computer Engineering
McMaster University, Hamilton, Ontario L8S 4L7

Email bandler@mcmaster.ca URL <http://soya.sos.mcmaster.ca>

Abstract

A new technique of Multiple Space Mapping is developed to align electromagnetic (EM) and empirical models of coupled interconnects. Simultaneous optimization of crosstalk and signal delay demonstrates the approach. Fast optimization supported by very few EM simulations is carried out with the speed of the empirical model and the accuracy of the EM model.

Introduction

In this paper we present new results for crosstalk and delay minimization for VLSI design. Following recent exciting developments our goal is to integrate EM simulators for automated interconnect design. Because of the inherent slowness of EM simulators we apply and extend the Space Mapping technique [1] which was conceived specifically for designs involving CPU intensive simulators.

Two coupled transmission lines are used to model a simple interconnect. Analog time-domain simulations of high-speed digital circuits involving such interconnects are carried out in two steps. First, the LC matrices (per unit length) of the coupled transmission lines are calculated. Then these matrices together with all other circuit elements are used in a circuit-level time-domain simulator, such as SPICE. In our work we use the AWE time-domain circuit-level simulator COFFEE2 from Carleton University to evaluate various circuit responses, including crosstalk. This simulation scheme clearly involves some intermediate parameters (here, the LC matrices). These intermediate parameters play a special role in the approach proposed in this paper.

A novel concept which we call Multiple Space Mapping is formulated to align an empirical model with accurate EM simulations. Several different mappings are established between the input parameter spaces of the empirical and EM models. All mappings are used simultaneously, each to determine different intermediate parameters. This concept is applied to the modeling of a two-conductor interconnect by creating two mappings: one targeting crosstalk and the other one targeting signal delay. Fast optimization of a circuit containing such interconnects can be carried out with the speed of the empirical model and the accuracy of the EM model.

This work was supported in part by the Natural Sciences and Engineering Research Council of Canada under Grants OGP0007239, OGP0042444 and STR0167080 and through the Micronet Network of Centres of Excellence.

The first three authors were formerly affiliated with Optimization Systems Associates Inc., Dundas, Ontario, Canada, before acquisition by HP EEsos. Dr. J.W. Bandler is currently affiliated with Bandler Corporation, P.O. Box 8083, Dundas, Ontario, Canada L9H 5E7. Drs. R.M. Biernacki and S.H. Chen are now with HP EEsos Division, Hewlett-Packard Company, 1400 Fountaingrove Parkway, Santa Rosa, CA 95403-1799.

Empirical and EM models of the Interconnects

We consider two ways of simulating the coupled transmission lines: (1) a set of empirical formulas (see, Walker, [2]), and (2) EM simulations using the *em* simulator from Sonnet Software [3]. The per-unit-length LC matrices of the coupled interconnects (transmission lines), as calculated using [2] and obtained from simulations by *em*, do not quite agree with each other [reference not included in this summary]. Simulations by *em* are considered to be accurate and hence are preferred as inputs to the circuit-level simulator. The empirical formulas on the other hand allow for extremely fast calculation of the LC parameters, and are therefore desirable for inclusion in repeated simulations during optimization.

The Concept of Multiple Space Mapping

Space Mapping [1] establishes a mathematical link between models of different complexity and accuracy. In the context of this paper two models are considered: Walker's formulas (a fast, "coarse" model) and simulations by *em* (fine model, accurate but slower). To align the two models, a mapping between the input spaces of both models is created and iteratively refined.

We extend this concept to Multiple Space Mapping. While the mathematical details are left out of this summary, the concept is outlined as follows. Consider the primary parameters ϕ_{em} and ϕ_{os} of the EM and empirical models, respectively, and a number of responses grouped into N subsets (or vectors) R^k , $k = 1, 2, \dots, N$. The responses are not limited to circuit performance functions, but they may also represent some intermediate parameters. Applying Space Mapping to these subsets of responses we establish N different mappings, each targeting one individual R^k . Consequently, one set of actual parameters ϕ_{em} is mapped to N different sets of input parameters $\phi_{os}^1, \phi_{os}^2, \dots, \phi_{os}^N$ for the empirical model.

The mappings are then incorporated into optimization in the following fashion. For every new point ϕ_{em} determined by the optimizer we find N mapped points ϕ_{os}^k and then N simulations of the coarse model are carried out, each for a specific ϕ_{os}^k and only to evaluate the corresponding R^k . Finally, the overall responses are assembled from those partial responses. The speed of a single circuit simulation is, therefore, equivalent to that of N simulations of the fast, empirical model. Furthermore, by assuring large enough validity regions for the mappings (quasi-global modeling) we can manage maintaining the accuracy of EM simulations.

Results of Multiple Space Mapping Optimization

We consider simultaneous crosstalk and delay optimization in the circuit shown in Fig. 1 [4]. Applying a 6 ns trapezoidal voltage to the circuit input we optimize the direct output signal V_{out} and the crosstalk signal V_{cross} to satisfy the following specifications:

$$V_{out}(t) > 0.95 \text{ at } t = 1.5 \text{ ns} \qquad -0.0025 < V_{cross} < 0.0025$$

First, two mappings are established between the parameters d , w , h and ϵ_r of the empirical model and those used in the simulations by *em*. The first mapping targets the direct signal while the second mapping targets crosstalk. The responses R^k considered in establishing the mappings are the LC parameters: the first group consists of the self inductance and the self capacitance, while the second group consists of the mutual inductance and the mutual capacitance. All lumped component values and the parameters of the coupled lines are considered as the optimization variables.

Minimax optimization was carried out by OSA90/hope [5]. Sonnet *em* simulations for establishing the mappings as well as for final verification of the results were performed using Empipe [5]. The circuit responses before and after optimization are shown in Fig. 2.

Conclusions

In the context of combining the respective advantages of EM simulations and empirical formulas for interconnect design we developed a novel Multiple Space Mapping technique. It has been successfully applied to simultaneous crosstalk and delay optimization. The optimization of an interconnect circuit is carried out with the speed of the empirical model while retaining the accuracy of EM simulations.

References

- [1] J.W. Bandler, R.M. Biernacki, S.H. Chen, P.A. Grobelny and R.H. Hemmers, "Space mapping technique for electromagnetic optimization," *IEEE Trans. Microwave Theory Tech.*, vol. 42, 1994, pp. 2536-2544.
- [2] C.S. Walker, *Capacitance, Inductance, and Crosstalk Analysis*. Norwood, MA: Artech House, 1990.
- [3] *em™* and *xgeom™*, Sonnet Software, Inc., 1020 Seventh North Street, Suite 210, Liverpool, NY 13088.
- [4] S. Lum, M.S. Nakhla and Q.J. Zhang, "Sensitivity analysis of lossy coupled transmission lines," *IEEE Trans. Microwave Theory Tech.*, vol. 39, 1991, pp. 2089-2099.
- [5] *OSA90/hope™* and *Empipe™*, formerly Optimization Systems Associates Inc., P.O. Box 8083, Dundas, Ontario, Canada L9H 5E7, now HP EEsof Division, Hewlett-Packard Company, 1400 Fountaingrove Parkway, Santa Rosa, CA 95403-1799.

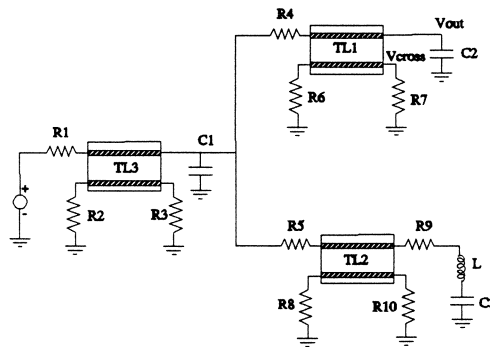

Fig. 1. The interconnect circuit for crosstalk and delay optimization.

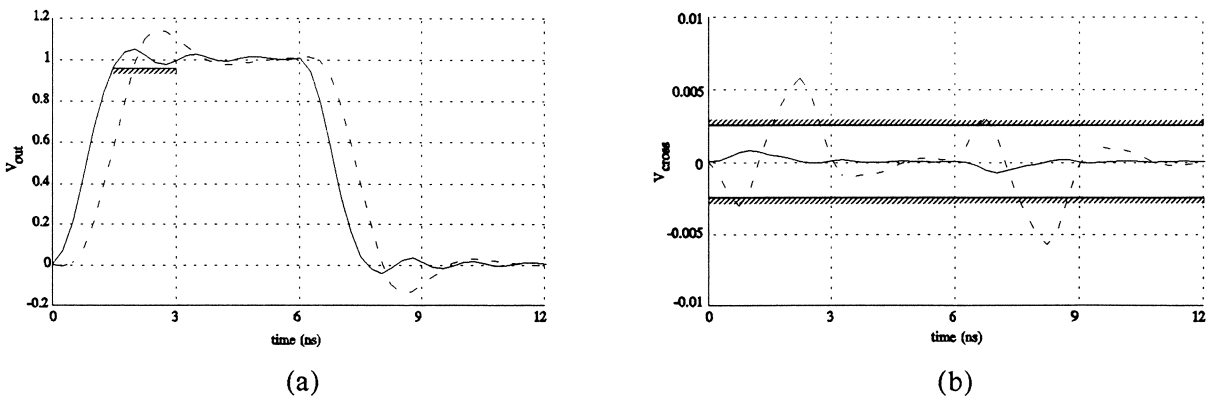

Fig. 2. (a) direct signal output V_{out} and (b) crosstalk waveforms V_{cross} before (----) and after (—) optimization.

