

ORGANO-TRANSITION METAL CHEMISTRY

SOME STUDIES
IN
ORGANO-TRANSITION METAL CHEMISTRY

By
COLIN CRINDROD, B.Sc.

A Thesis
Submitted to the Faculty of Graduate Studies
in Partial Fulfilment of the Requirements
for the Degree
Master of Science

McMaster University

October 1966

MASTER OF SCIENCE (1966)
(Chemistry)

MCMASTER UNIVERSITY
Hamilton, Ontario

TITLE: Some Studies in Organo-Transition Metal Chemistry

AUTHOR: Colin Grindrod, B.Sc. (Manchester University)

SUPERVISOR: Dr. P. M. Maitlis

NUMBER OF PAGES: iv, 71

SCOPE AND CONTENTS: The work described is an extension of the ligand-transfer reactions of substituted cyclobutadienes and cyclopentadienyls previously carried out by Maitlis et al. Efforts were directed particularly to ligand-transfer reactions of π -allyl-transition metal complexes. The reactions of organic halides with metal carbonyls were also studied in attempts to isolate new organometallic derivatives.

ACKNOWLEDGEMENTS

The author wishes to express his sincere gratitude for the stimulating advice and constant encouragement provided by Dr. P. M. Maitlis, under whose guidance this work was carried out. Thanks are also extended to Imperial Oil Co. Ltd. for providing the financial support which made this study possible.

CONTENTS

	<u>Page</u>
INTRODUCTION	
Historical.....	1
Cyclobutadiene-transition metal complexes...	7
Ligand-transfer reactions.....	10
Allyl-transition metal complexes.....	13
Reactions of metal carbonyls with organic halides.....	25
DISCUSSION	
I. Ligand-transfer reactions.....	29
II. Reactions of metal carbonyls with organic halides.....	39
EXPERIMENTAL	
I. Ligand-transfer reactions.....	48
II. Reactions of metal carbonyls with organic halides.....	55
APPENDIX.....	61
BIBLIOGRAPHY.....	67

INTRODUCTION

INTRODUCTION

Historical

In recent years, unusually stable organometallic derivatives of the transition metals have been prepared in which the metal atom utilises π -electrons from a suitable organic ligand to achieve, usually, the stable closed-shell configuration of the next rare gas. Transition metal complexes of this nature are known which contain between two and eight carbon atoms bonded to the metal. Some examples are given in the following table.

Number of π -electrons utilised	Type of complex	Example
2	Olefin	$K^+ [C_2H_4PtCl_3]^-$ (1) ethylene-platinum trichloride anion
3	π -Allyl	$(\pi-C_3H_5)_2Ni$ (2) bis(π -methallyl)nickel
4	Cyclobutadiene	$Ph_4C_4Fe(CO)_3$ (3) tetraphenyl-cyclobutadieneiron tricarbonyl
5	Cyclopentadienyl	$(\pi-C_5H_5)_2Fe$ (4) ferrocene
6	Benzene	$(C_6H_6)_2Cr$ (5) dibenzenechromium
7	Cycloheptatrienyl	$(\pi-C_7H_7)V(\pi-C_5H_5)$ (6) π -cycloheptatrienyl- π -cyclopentadienylvanadium
8	Cyclooctatetraene	$(C_8H_8)Fe(CO)_3$ (7) cyclooctatetraeneiron tricarbonyl

The olefin complex (1) has a square planar arrangement of ligands around the platinum atom,^{1,2} with the olefin perpendicular to the plane of the complex.³

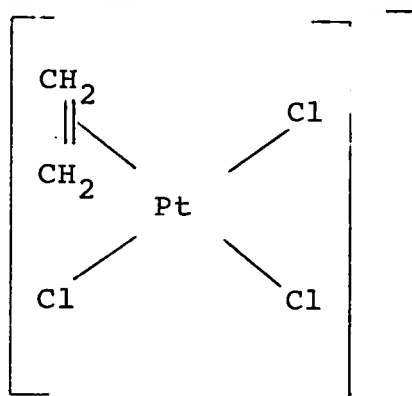

(1)

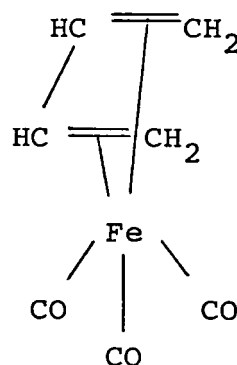

(8)

Many poly-olefin complexes, such as butadieneiron tricarbonyl⁴ (8) have also been prepared. The complex (8) has all four carbon atoms approximately equi-distant from the iron,⁵ and has a structure very similar to all of the following examples. However, the bonding in olefin-metal complexes is more conveniently explained by considering the mono-olefin complex (1). The presently accepted view of the bonding in olefin-metal complexes was first formulated by Dewar⁶ for the silver-olefin complexes, and these ideas have been extended by Chatt⁷ to the platinum-olefin complexes.

The platinum-olefin bond is believed to consist of a σ -type bond formed by overlap of a vacant dsp^2 orbital of the platinum with a filled π -2p orbital of the olefin, and a π -bond formed by overlap of a filled dp orbital of the platinum with a vacant π^* -2p antibonding orbital of the

olefin (Fig. 1). The π -bonding tends to remove negative charge from the metal which would otherwise accumulate owing to the σ -bond.

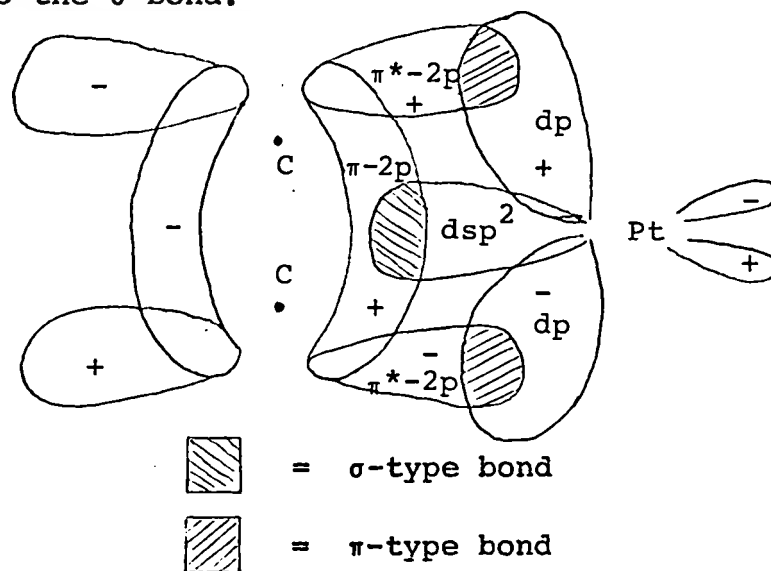
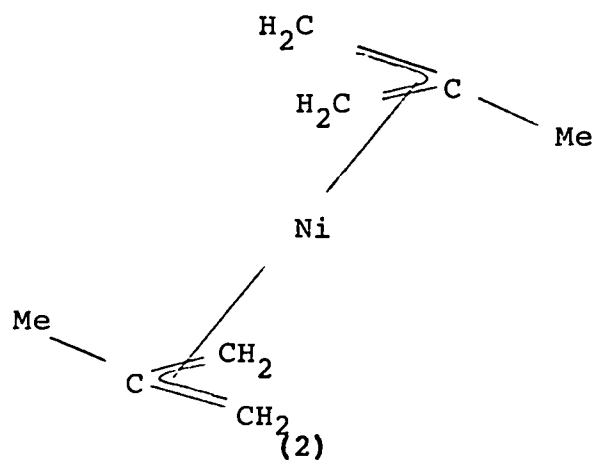

Fig. 1. A pictorial representation of the bonding in platinum-olefin complexes

A very similar type of bonding is believed to occur between an allyl group and a metal in the π -allylic complexes, such as bis(π -methallyl)nickel (2). In other words, the allyl group donates its π -electrons to the metal atom in a σ -type bond and accepts electrons from the metal into its antibonding π^* molecular orbitals in a π -type bond. X-ray analysis^{8,9} of the complex (2) has confirmed the "sandwich"-type structure, and has also shown that the methyl groups are trans to each other. Three carbon atoms in each methallyl group are situated at about the same distance from the central nickel atom, and the methyl groups are inclined towards the metal at an angle of about 12° to the planes of the allyl groups.



The bonding in this complex and in all of the other "sandwich" or "half-sandwich" compounds to be described is qualitatively very similar, the only real difference being in the particular orbitals utilised.

According to molecular orbital theory, square cyclobutadiene in its ground state has two unpaired electrons in a doubly degenerate orbital, and it was suggested by Longuet-Higgins and Orgel¹⁰ that both might be used to form π -bonds to a transition metal. The preparation of tetraphenylcyclobutadieneiron tricarbonyl¹¹ (3) has helped to show that this prediction is correct. An X-ray structure determination^{12,13} has confirmed that the structure is the "half-sandwich" one shown.

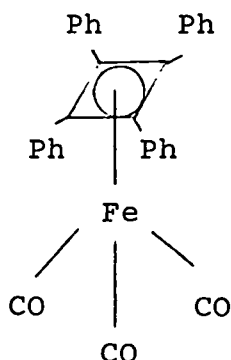

(3)

Ferrocene (4) was initially discovered in 1951 by two independent groups of workers,^{14,15} but its "sandwich" structure was not suggested until the following year, by a third group of workers.¹⁶ This suggestion was soon confirmed by X-ray measurements,^{17,18,19,20} which also showed that the cyclopentadienyl rings in the solid are in the "staggered" conformation.^{19,20}

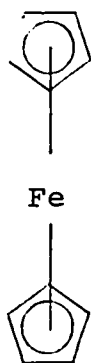

(4)

Very similar structures are exhibited by dibenzenechromium²¹ (5), which has all six carbon atoms of each benzene ring equivalently bonded to the metal, and by π -cycloheptatrienyl- π -cyclopentadienylvanadium²² (6), which has all seven carbon atoms of the seven-membered ring

equivalently bonded to the metal, and all five carbon atoms of the cyclopentadienyl ring also equivalently bonded to the metal. The five- and seven-membered rings in this latter compound are in the "eclipsed" conformation.

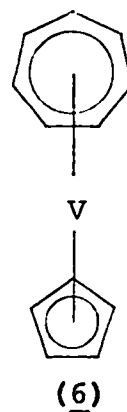
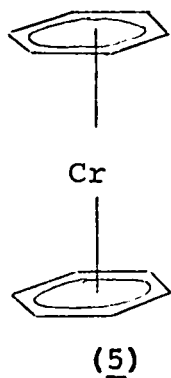

The "half-sandwich" structure has also been found for cyclooctatetraeneiron tricarbonyl (7), but the cyclooctatetraene ring is bent away from the metal atom,^{23,24} as shown, so that the iron is essentially bonded only to four of the carbon atoms of the ring.

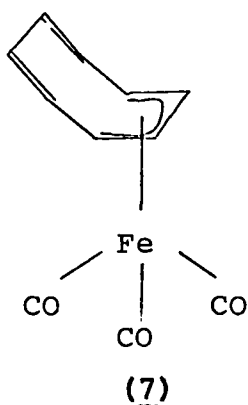

Cyclobutadiene--transition metal complexes

The formation of transition metal complexes of the nature described has a great effect upon stability. For instance, it has not been found possible to produce any stable simple cyclobutadiene derivatives, although much evidence for their existence as intermediates in some reactions has been accumulated. A great deal of the more recent work in this connection has been carried out by Pettit and his co-workers,^{25,26,27} following their preparation of cyclobutadieneiron tricarbonyl²⁸ (9), the first metal complex of cyclobutadiene itself to be prepared.

It has been found that the complex (9), in the presence of cerium (IV) (which oxidises the $\text{Fe}(\text{CO})_3$ group to $\text{Fe}(\text{III})$) and acetylenic compounds, for instance, yields products that would be expected from the addition of an acetylene to cyclobutadiene, and these reactions are believed to occur via free cyclobutadiene as an intermediate.

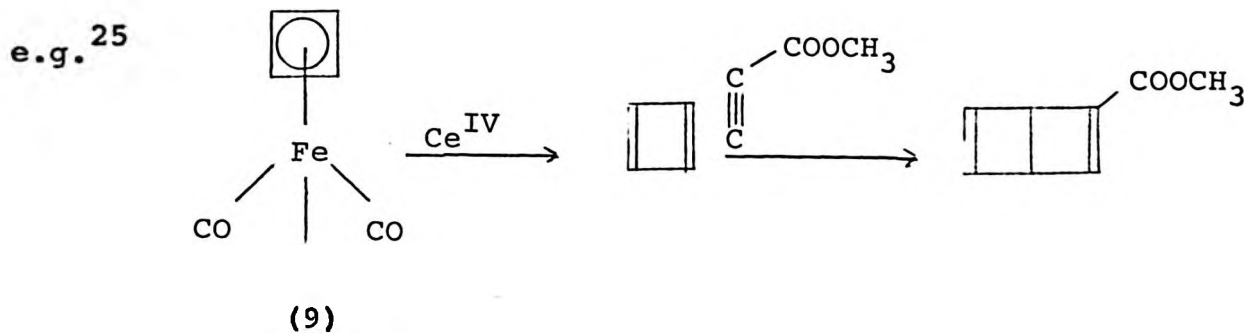

The complex (9) is one of the many cyclobutadiene-metal complexes now known that have confirmed the suggestion by Longuet-Higgins and Orgel¹⁰ in 1956 that it should be

possible to stabilise cyclobutadienes by bonding to a transition metal. One of the first of the cyclobutadiene-metal complexes to be prepared was tetraphenylcyclobutadieneiron tricarbonyl¹¹ (3), which was prepared in 16% yield by reacting diphenylacetylene with iron pentacarbonyl at high temperature (eqn. 1). The major product of this reaction was a tetracyclone complex (10).

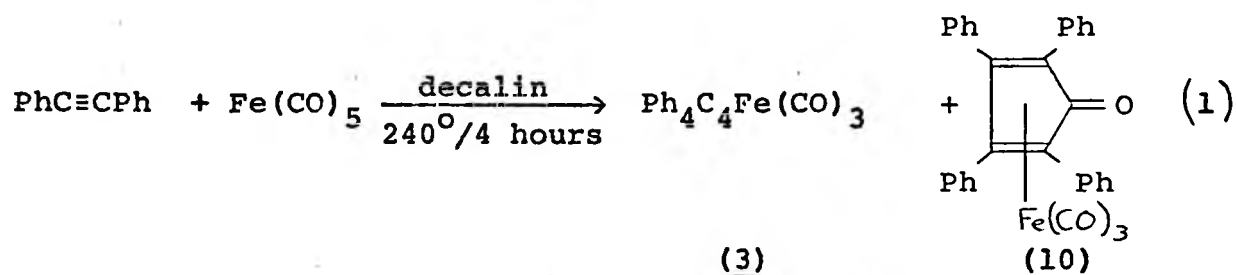

Reactions of acetylenes with metal carbonyls have been extensively studied and, in general, mixtures of products are obtained, usually difficult to separate, so that these reactions are not often useful synthetically. However, the reaction of acetylenes with palladium chloride in ethanol or methanol, first studied by Malatesta *et al.*,²⁹ has yielded interesting results.

The product of the reaction is an ethoxytetraphenylcyclobutenyl-palladium chloride dimer (11), which has subsequently been shown by X-ray measurements³⁰ (11, R=Ph, R'=C₂H₅) to have the structure shown, with the ethoxy group endo-to (on the same side as) the metal.

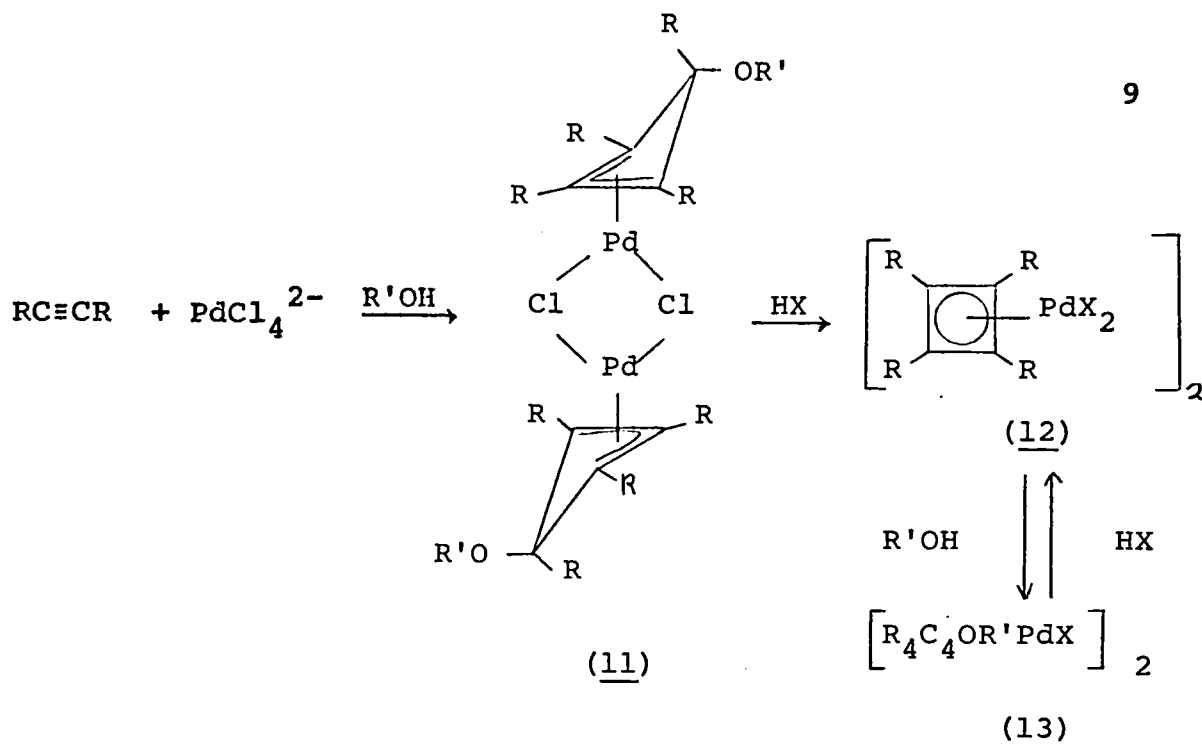

The cyclobutenyl complexes (11) react with hydrogen halides to give tetraphenylcyclobutadienepalladium halides³¹ (12, R=Ph, X=halogen). The complexes (12) react with alcohols to give cyclobutenylpalladium complexes (13), isomeric with (11). This last reaction is reversible upon treatment of (13) with hydrogen halides.

An X-ray structure determination³⁰ of (13, R=Ph, R'=C₂H₅, X=Cl) has shown it to have the same structure as (11), except that the ethoxy group is exo- to the metal (14).

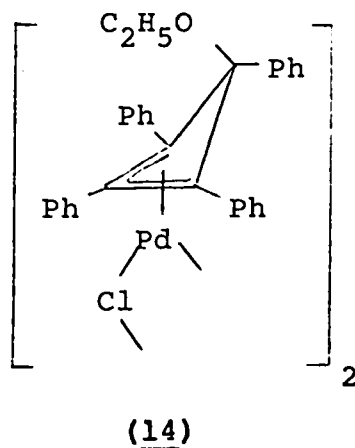

These cyclobutenyl complexes are members of the π -allylic group of compounds, the chemistry of which is discussed in a later section.

Ligand-transfer reactions

As with most other methods of synthesising cyclobutadiene-metal complexes, the methods described above for preparing the complex (12) involve an acetylene in the reaction. Such reactions suffer from the disadvantage that they are highly specific, both with regard to the metal and to the acetylene. Fortunately, however, the synthesis of cyclobutadiene-metal complexes, especially of tetraphenylcyclobutadiene complexes, has been greatly simplified by the discovery of ligand-transfer reactions.

The first example of the conversion of one hydrocarbon-transition metal complex into another by direct ligand-transfer was the reaction of tetraphenylcyclobutadienepalladium bromide (15) with iron pentacarbonyl or nickel carbonyl to produce tetraphenylcyclobutadieneiron tricarbonyl (3) or tetraphenylcyclobutadienenickel bromide (16) respectively.³² This method has since been extended and Fig. 2 shows some of the main reactions that have been carried out.^{32,33,34,35}

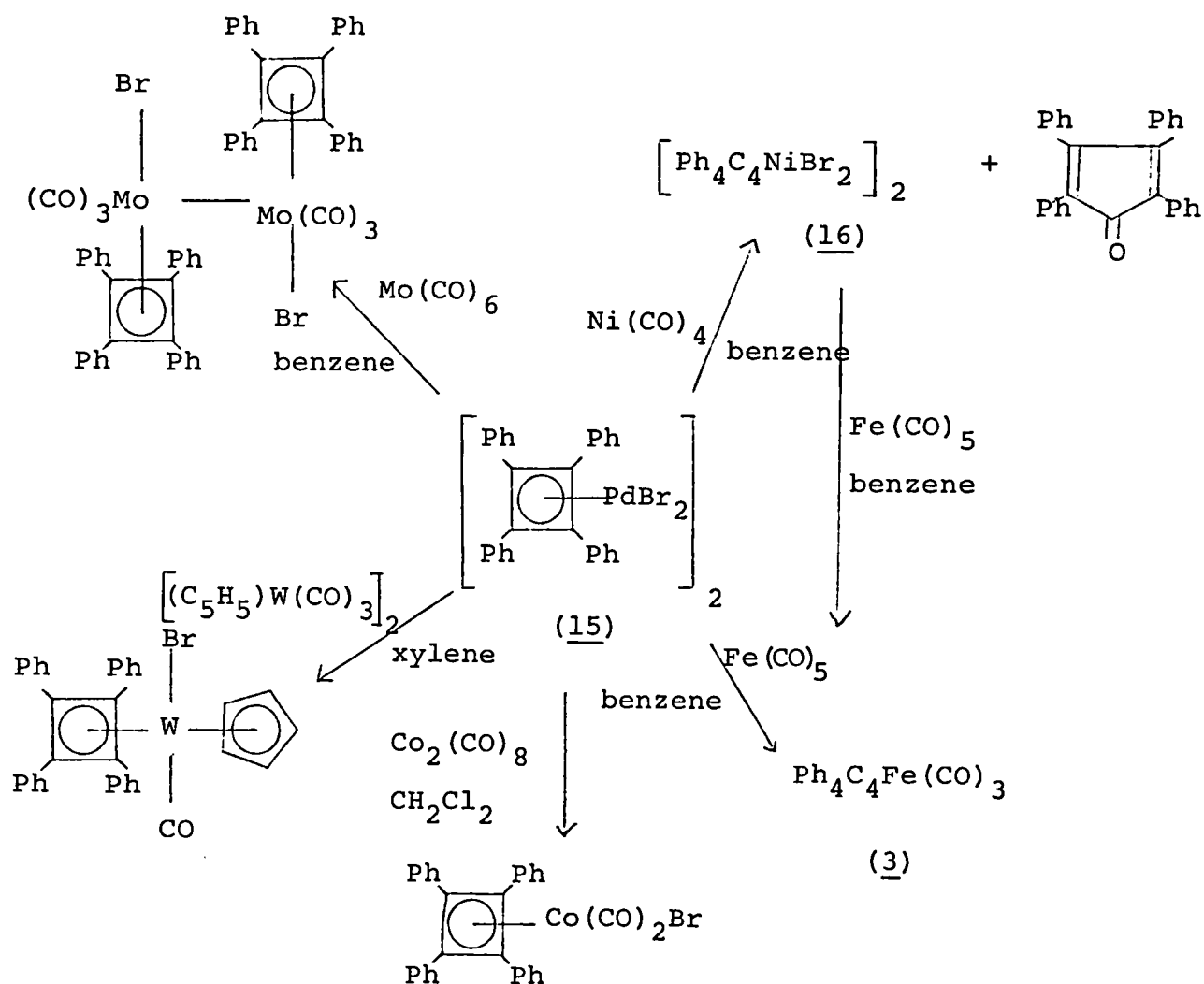
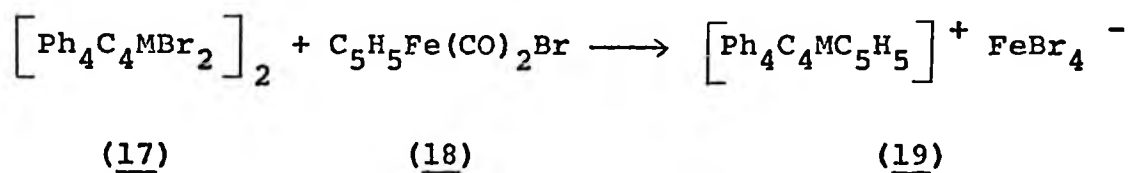

Fig. 2. Synthesis of cyclobutadiene-metal complexes by ligand-transfer reactions.

In general, the cyclobutadiene group is transferred from palladium on to another metal. However, reaction of tetraphenylcyclobutadienenickel bromide (17, M=Ni) or tetraphenylcyclobutadienepalladium bromide (17, M=Pd) with cyclopentadienyliron dicarbonyl bromide (18) leads to transference of the cyclopentadienyl group rather than the

tetraphenylcyclobutadiene group, and the respective products are π -cyclopentadienyl-tetraphenylcyclobutadiene-nickel tetrabromoferrate (19, M=Ni) and π -cyclopentadienyl-tetraphenylcyclobutadienepalladium tetrabromoferrate^{36,37} (19, M=Pd).



These ligand-transfer reactions are usually carried out under heterogeneous conditions, and no meaningful data on their mechanisms have yet been obtained. However, in the reactions illustrated in Fig. 2, where the metal carbonyls function as dehalogenating agents, two main steps can be envisaged,³⁸ which can be described in general terms. The first step is probably complex formation between the metal carbonyl and the cyclobutadienepalladium halide, possibly with loss of carbon monoxide, and the second step must be transfer of the cyclobutadiene from the palladium on to the other metal, with loss of carbon monoxide. However, the formation of organic side-products in some of these reactions suggests that while the first step leading to the break-up of the palladium complex is always efficient, the second step is sometimes very difficult.

Apart from the formation of (19, M=Pd or Ni) described above, many other examples of transfer of the

cyclopentadienyl ligand from one transition metal to another are known. For instance, the transfer of the cyclopentadienyl ligand from iron on to palladium, nickel, cobalt and titanium, as well as the reverse reaction from titanium to iron, has been reported.³⁶ The cyclopentadienylating agents used have been cyclopentadienyliron dicarbonyl bromide (18) and cyclopentadienyliron dicarbonyl dimer (20).

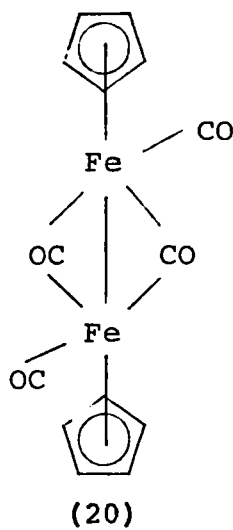

The reactions appear to go particularly well when the reactant has a π -bonded hydrocarbon ligand such as tetraphenylcyclobutadiene, and a number of π -cyclopentadienyl- π {tetraphenylcyclobutadiene}metal complexes have been prepared.

Allyl-transition metal complexes

On the basis of their nmr spectra, four different types of allylmetal systems have been distinguished. The

first type are very similar to the σ -alkylmetal compounds, and have a conventional σ -bond between the metal and the allyl group; such compounds are known as σ -allylmetal compounds, a good example being σ -allylmanganese pentacarbonyl^{39,40} (21), prepared by treating allyl chloride with sodium manganese pentacarbonyl.

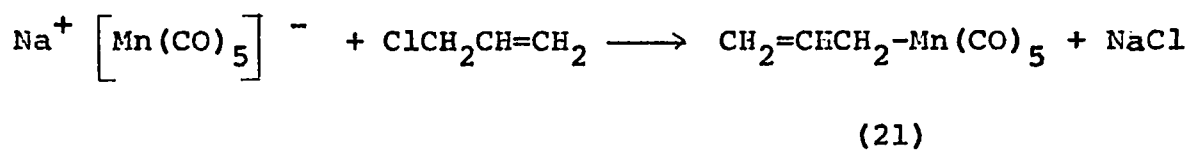

The σ -allyl complexes of transition metals are usually yellow oils, insoluble in water, but very soluble in non-polar solvents. Irradiation of any of the reported σ -allylmetal carbonyl complexes with ultra-violet light results in the displacement of carbon monoxide from the metal and formation of a π -allyl derivative (22), as in eqn. 2.⁴¹

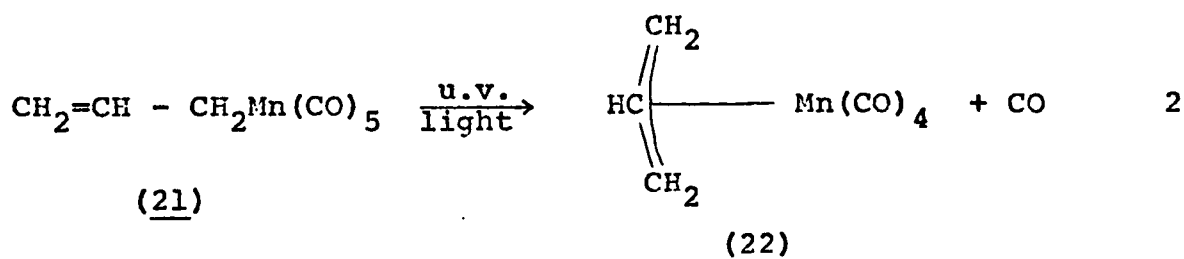

The proton nmr spectra of σ -allylmetal compounds show four resonances,⁴⁰ which arise as follows; the aliphatic CH_2 is coupled with the vinyl CH to give a doublet; the hydrogen atoms in the vinyl CH_2 group are non-equivalent and each is split by the vinyl CH into doublets; the vinyl

CH hydrogen atom gives rise to a multiplet due to coupling with the aliphatic CH₂ and vinyl CH₂ hydrogen atoms.

Allylmagnesium bromide (23), expected to be a σ -allyl complex, gives an nmr spectrum containing only two signals -- a quintet and a doublet, with intensity ratio 1:4. This must mean that the protons of the CH₂ groups are indistinguishable, and this can only be interpreted⁴² if the equilibrium between the forms (23a) and (23b) is assumed to be very rapid.



Thus, the two possible covalent forms of the Grignard reagent are in dynamic equilibrium, and the lifetime of each form is long enough to permit rotation around its 1,2 carbon-carbon bond. More of these so-called "dynamic" allylmetal compounds have subsequently been prepared, usually of the main group metals.

A third type of allyl-metal bonding occurs in the π -allylmetal compounds, where the allyl radical may be regarded as contributing three electrons to the metal-allyl bond. In 1958, Jonassen *et al.*⁴³ prepared a compound from the reaction of cobalt hydrocarbonyl with butadiene, which they formulated as Co(CO)₃(C₄H₇), but no speculation upon its structure was offered. Later, Smidt and Hafner⁴⁴

reacted palladium chloride with allyl alcohol and obtained a chloro-bridged complex (24), but again the bonding of the allyl group to the metal was not discussed.

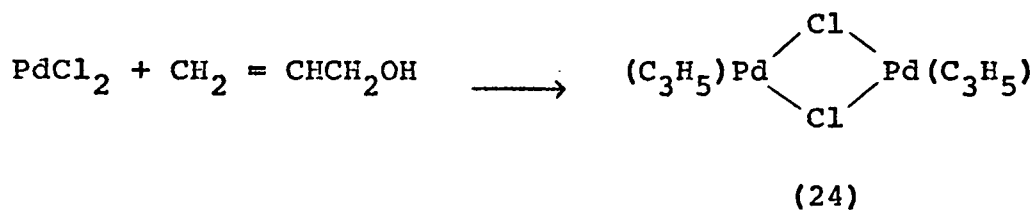

The complex (24) was also obtained⁴⁵ from the reaction of palladium chloride with allyl chloride in 50% acetic acid. Subsequently, Heck and Breslow⁴⁶ reported the preparation of allylcobalt tricarbonyl (25) from the reaction of sodium cobalt tetracarbonyl with allyl bromide in ether. On the basis of the nmr spectrum of the product, which showed three signals with intensity ratio 1:2:2, it was suggested that the allyl group was bonded symmetrically to the metal atom, although the evidence was not sufficient to distinguish unequivocally between (25a) and (25b). However, the structure (25a) was favoured.

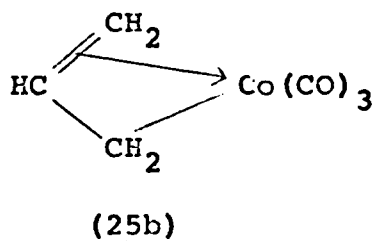
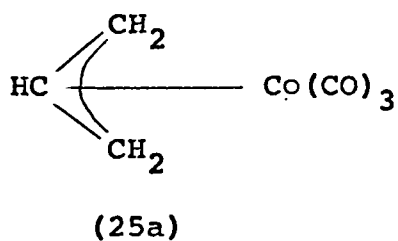

Finally, Dehm and Chien⁴⁷ carried out an nmr study of allylpalladium chloride (24) and found three types of

protons with intensity ratio 1:2:2. They proposed a "non-classical" structure in which the allylic group is symmetrically bonded to the palladium atom in a delocalised fashion, in similar manner to the proposed structure (25a) for the cobalt complex.

X-ray structural analyses^{48,49,50} of π -allyl-palladium chloride have confirmed that the allyl groups are symmetrically bonded to the metal, with the carbon atoms of each allyl group in a plane perpendicular to that containing the palladium and chlorine atoms (26).

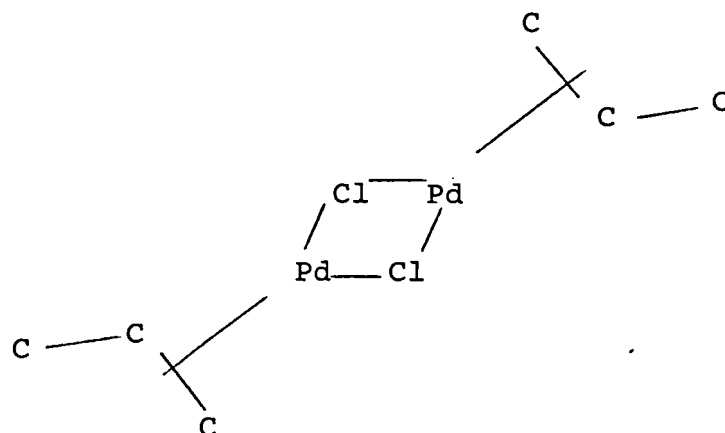

(26)

It has been pointed out⁵¹ that in π -allyl compounds there should be considerable energy barrier to rotation about the carbon-carbon bonds in the allylic group, and therefore two isomers (27) and (28) should be possible in a terminally substituted π -allyl group.

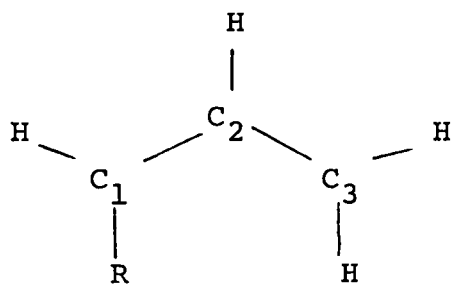

(27)

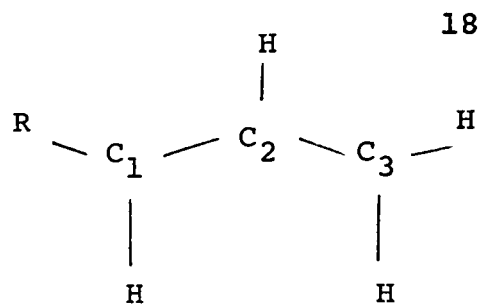

(28)

This has been borne out experimentally. For instance, the complex $\text{C}_4\text{H}_7\text{Co}(\text{CO})_3$ mentioned earlier, is formed as a mixture of geometrical isomers of π -crotyl-cobalt tricarbonyl (29, a=anti isomer, b=syn isomer).

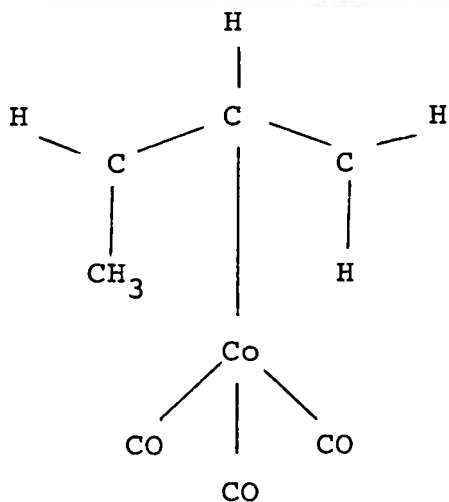

(29a)

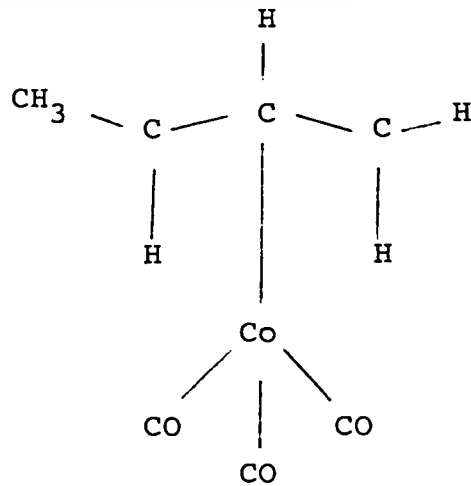

(29b)

The fourth kind of allylmetal complex is obtained from the reaction of triphenylphosphine with π -methallyl-palladium chloride (30) in benzene or acetone solution, when the reactants are present in a ratio of 1:1.⁵²

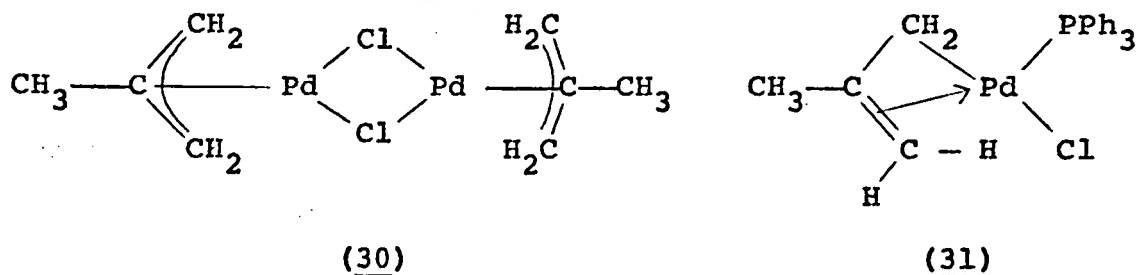

The product of this reaction, a stable crystalline monomeric complex PdCl(methallyl)(PPh₃), gives an nmr spectrum showing three broad doublets and one sharp singlet, with intensity ratio 1:1:2:3. It was suggested that this compound has a structure approximating to (31), intermediate between a π - and a σ -methallyl complex, with two carbon atoms only weakly bonded to the palladium. This structure has subsequently been confirmed by an X-ray analysis.⁵³

If the reaction between (30) and triphenylphosphine is carried out in chloroform solution with a 2:1 ratio of triphenylphosphine: palladium,⁵² the product gives an nmr spectrum containing only two sharp singlets, indicating the formation of a "dynamic" allyl complex. This transition from π -allylmetal complex to "dynamic" allylmetal complex is not the only transition that has been reported for the

allylmetal complexes. The nmr spectrum of tetrakis(allyl) zirconium, ⁵⁴ Zr(allyl)₄, in CFCl₃ solution over a range of temperatures from -74°C to 0°C, changes from one typical of a π-allyl complex to one typical of a "dynamic" allyl complex. It is suggested that this complex is really a π-bonded "dynamic" allyl complex, and differs from the usual π-allyl complexes only in having hindered rotation of the CH₂ groups about the carbon-carbon bonds linking them to the central carbon atom -- a rotation that occurs at a rate dependent on the temperature.

It has been suggested⁵⁵ that the relative ease of internal rotation in Zr(allyl)₄ (in contrast to the majority of π-allylmetal complexes) is explained by the absence of d-electrons available for back-donation to the allyl groups.

The chemistry of π-allylmetal complexes has expanded rather more rapidly than that of any of the other allylmetal types, and several general methods are available for preparing π-allyl or the more simply substituted π-allylic complexes.

One method has already been mentioned: the preparation of σ-allylmanganese pentacarbonyl (21), followed by u.v. irradiation to form the π-allyl complex (22) (eqn. 2). Many other π-allyl complexes have been obtained in this fashion, in some cases, for instance in

the preparation of π -allylcobalt complexes, only the π -allyl complexes being isolated, the intermediate σ -allyl complexes being very unstable and easily decomposing at low temperatures.

The reaction of palladium chloride with allyl chloride in 50% acetic acid⁴⁵ to produce π -allylpalladium chloride has also been extended to other allyl halides.

Olefin-metal complexes have been found in some cases to function as intermediates in the formation of π -allylmetal complexes. Examples are given in eqn. 3⁵⁶ and eqn. 4.⁵⁷

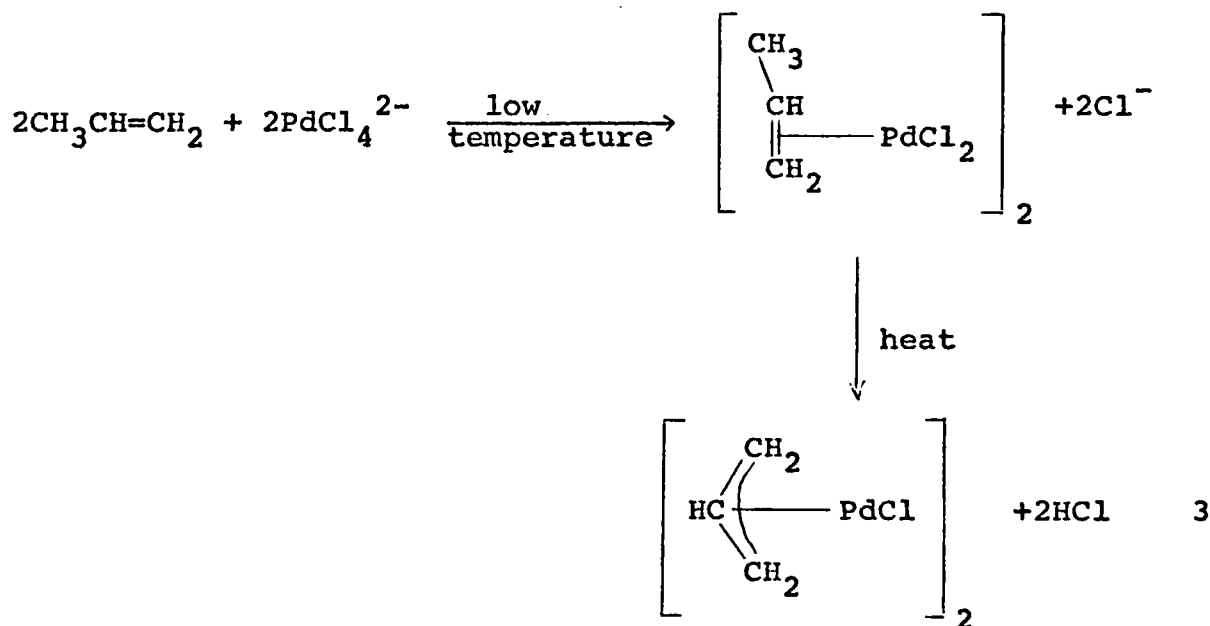

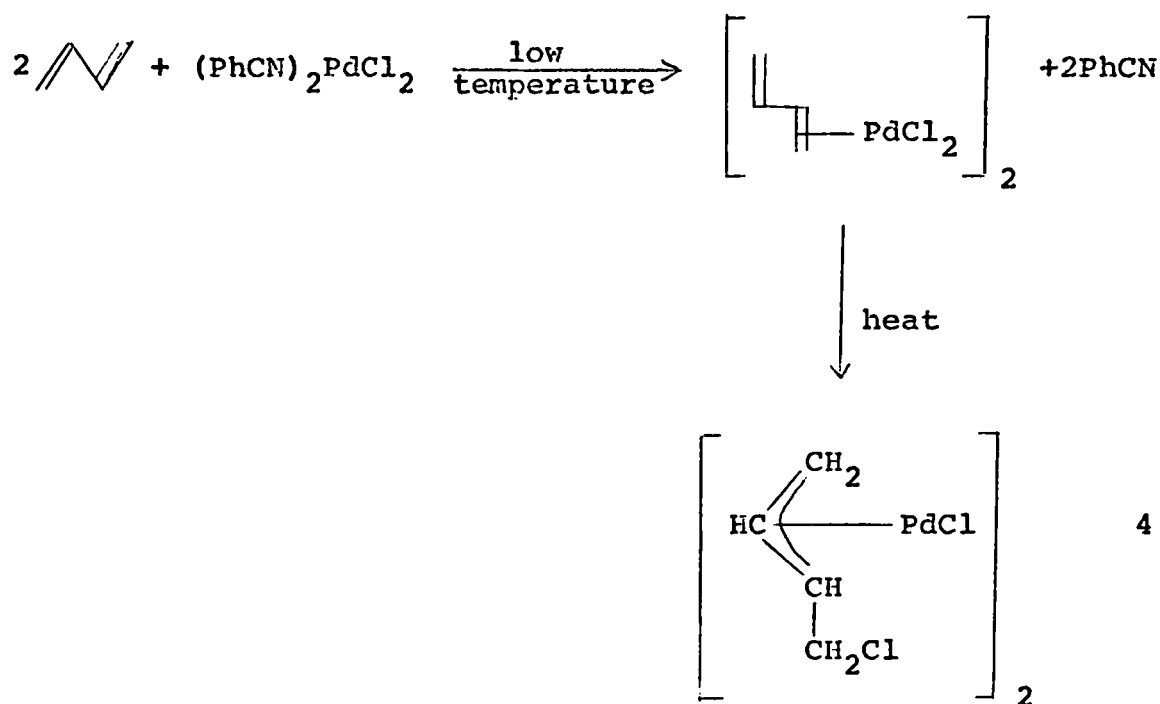

A number of methods for the preparation of π -allyliron tricarbonyl halides have been reported. The reaction of butadieneiron tricarbonyl (8) with anhydrous hydrogen chloride yields π -crotyliron tricarbonyl chloride⁵⁸ (33, X=Cl).

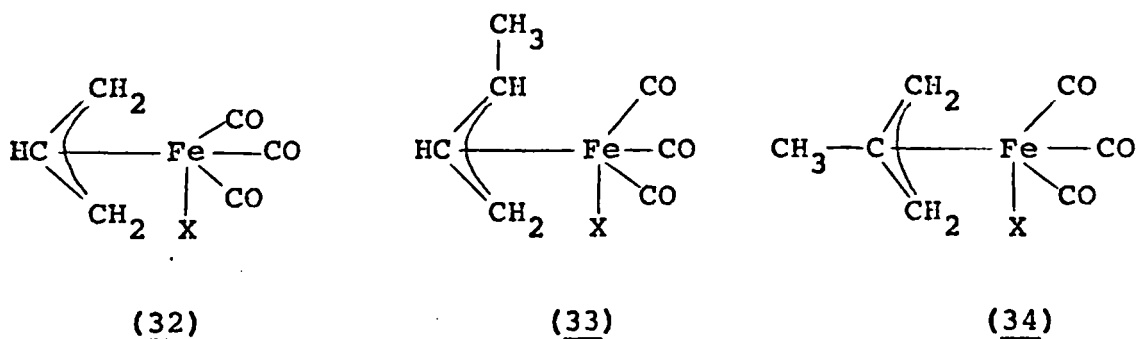

π -Methallyliron tricarbonyl iodide (34, X=I) can be prepared by the reaction of methallyl iodide with iron

pentacarbonyl at 40°C.⁵⁹ The reaction of iron nonacarbonyl, $\text{Fe}_2(\text{CO})_9$, with allyl or crotyl halides at 40°C⁶⁰ also leads to the corresponding π -allyliron tricarbonyl halides (32, X=Cl,Br,I) or π -crotyliron tricarbonyl halides (33, X=Cl,Br,I) respectively. All of these latter compounds can also be prepared by u.v. irradiation of pentane solutions of iron pentacarbonyl with the allylic halides, at room temperature.⁶¹

The properties of π -allylmetal complexes cover a wide range; for instance, the thermal stability of π -allylic complexes varies from the very stable complexes of palladium, which are often stable above 200°C, to the very unstable and incompletely characterised tris(π -allyl) complexes of chromium and iron. Most π -allylic complexes are oxidised by atmospheric oxygen, especially in solution, though in some cases decomposition only occurs after several hours exposure. Not surprisingly, in view of their stability, the largest series of π -allylic complexes of any metal is formed by palladium. The majority of these, most of them readily prepared, are chloro-bridged complexes of the type $[\text{PdCl}(\text{all})]_2$, where "all" = allylic group.

One of the general methods utilised for the preparation of these chloro-bridged palladium complexes is the reaction of the allylic chloride with sodium chloropalladite and carbon monoxide in aqueous methanol.⁶² Recently, a

mechanism has been proposed for this reaction,⁶³ which suggests that the water present is directly involved in the reaction. One molecule of carbon monoxide is found to be oxidised to carbon dioxide, per palladium atom, and the mechanism proposed is the following:-

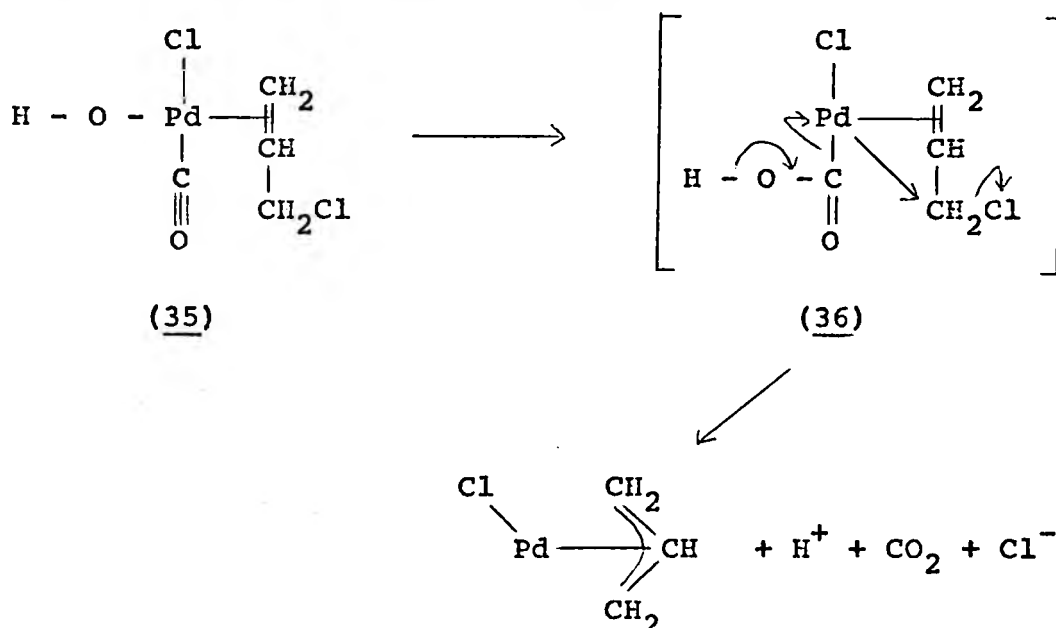

The allyl chloride, carbon monoxide and water all coordinate to the palladium, but since coordinated water is quite acidic, some of the hydroxo-species (35) will be formed. Hydroxyl migration (or carbon monoxide insertion) then gives the carboxylate complex (36) which breaks down as shown. The π -allyl complex formed, immediately dimerises.

Reactions of metal carbonyls with organic halides

It is a long-established fact that certain metal carbonyls react with halogenated organic compounds. Criegee and Schröder⁶⁴ took advantage of the known ability of nickel carbonyl to remove the chlorine from allylic chlorides, to prepare tetramethylcyclobutadienenickel chloride (38) from 3,4-dichlorotetramethyl-cyclobutene (37).

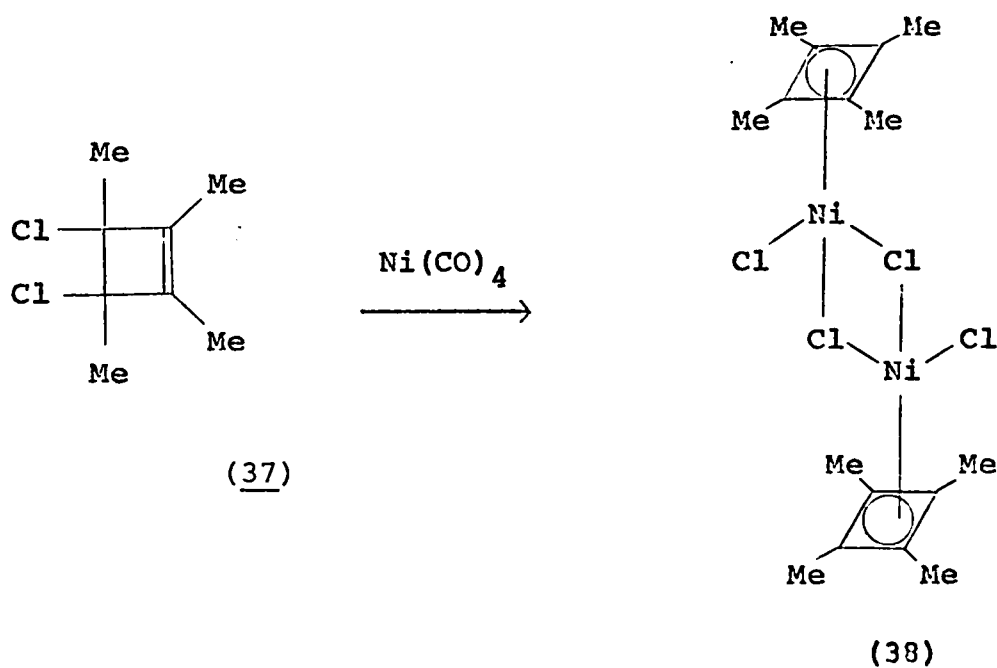

Recently,⁶⁵ it has been found that the organic fragment trimethylenemethane, unstable in its free state, can be stabilised in similar fashion to cyclobutadiene by bonding to a transition metal. The compound trimethylenemethaneiron tricarbonyl (40) has been prepared by reaction of 3-chloro(2-chloromethyl)propene (39) with excess iron nonacarbonyl.

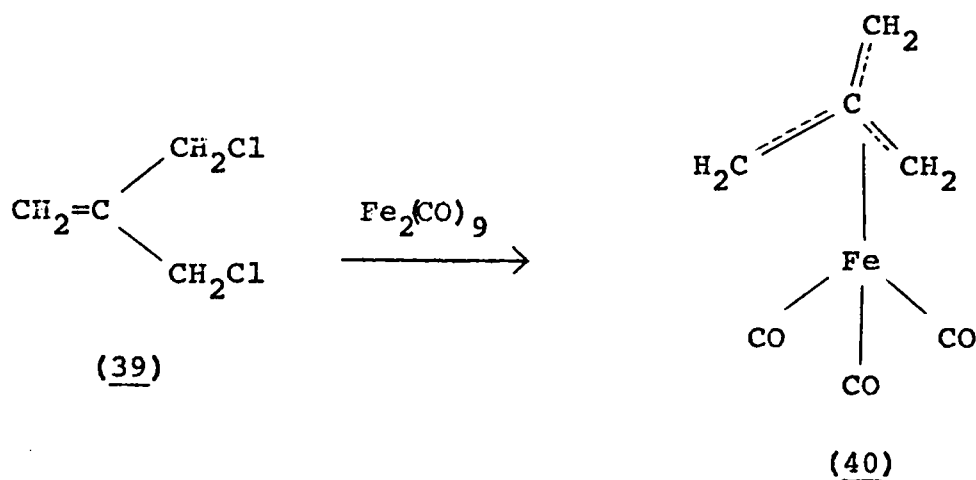

In 1963, Bauld⁶⁶ reported the reaction of nickel carbonyl with benzoyl chloride, benzoyl bromide, and a number of aryl iodides. The products obtained are dependent upon the solvent used, but are all postulated to arise from the same non-isolable organometallic intermediate (41). The full scheme of reaction is shown in Fig. 3.

Aryl iodides are converted to arylate esters (42) in alcoholic solvents (R= methyl, ethyl or iso-propyl), the yields being almost quantitative. In aprotic solvents (e.g. THF) the products are aryls (43), again obtained in excellent yield. Benzoyl chloride and benzoyl bromide are converted to 1,2-dibenzoyloxystilbene (44, Ar=Ph) via the compound benzil (43, Ar=Ph) in the aprotic solvents THF and hexane. All of the observed products can be viewed as arising from transformations of the postulated intermediate (41).

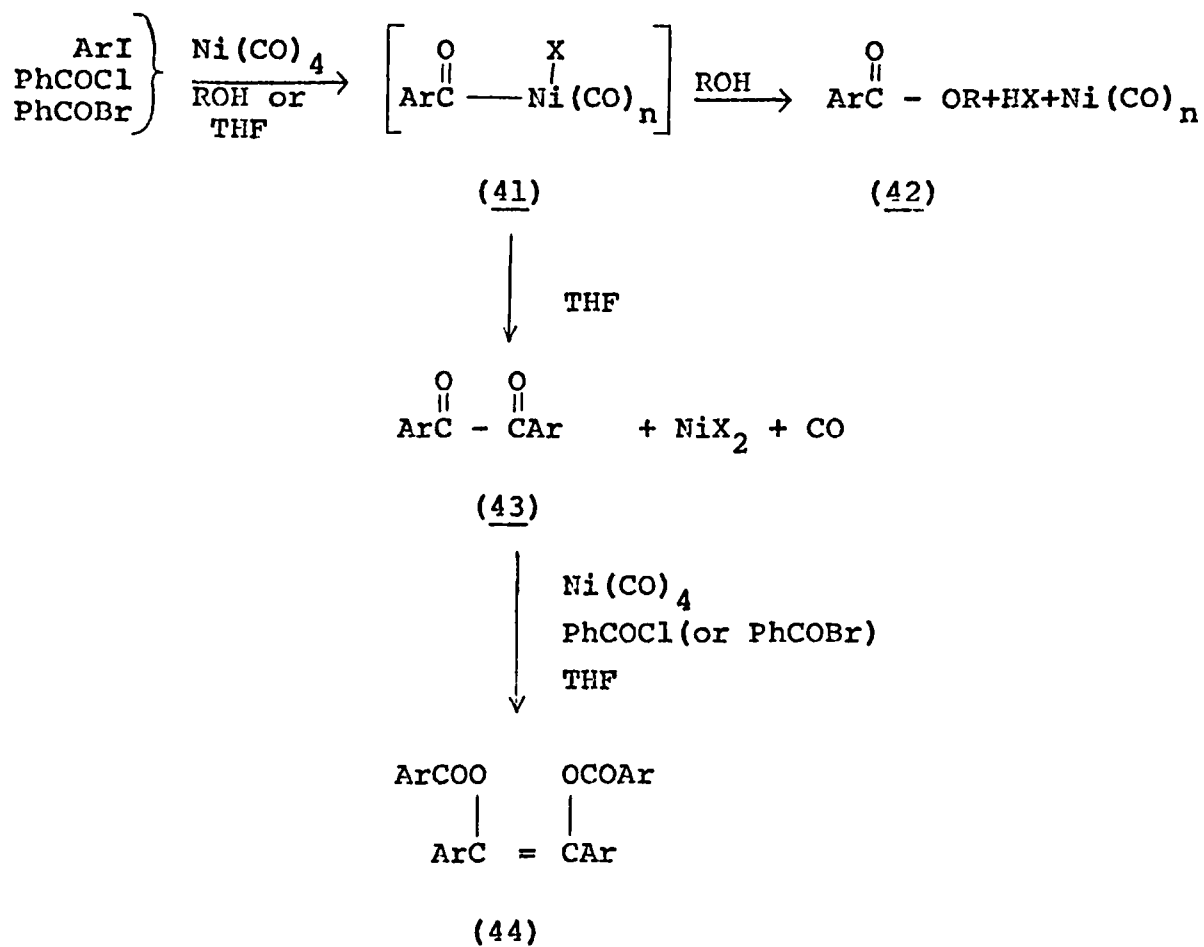
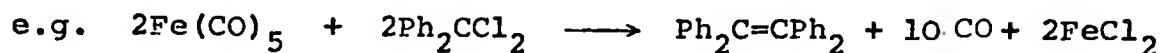

Fig. 3. Reactions of nickel carbonyl with some organic halides

Coffey⁶⁷ has reported the reaction of iron pentacarbonyl with gem-dihalides of the type R_2CX_2 , where R is phenyl, cyano, carbalkoxy or halogen, and X is chlorine or bromine. With $\text{R} = \text{p-R}'\text{C}_6\text{H}_4$ (where $\text{R}' = \text{hydrogen, methyl, t-butyl, methoxy, chloro or nitro}$) the reaction gives tetrasubstituted tetraphenylethylenes, $(\text{p-R}'\text{C}_6\text{H}_4)_2\text{C}=\text{C}(\text{p-R}'\text{C}_6\text{H}_4)_2$



With other R groups the reaction products are more complex.

From the series of reactions carried out, it has been found that iron pentacarbonyl reacts with organic halides (in refluxing benzene) if two conditions are met:-

- (1) the halide is activated by at least one, and preferably two, groups such as cyano, carbalkoxy, phenyl or halogen.
- (2) there are at least two halogens on the same carbon atom or in very close proximity to each other.

The second condition suggests that the reaction with gem-dihalides involves a carbene intermediate. However, treating dichlorodiphenylmethane with iron pentacarbonyl in the presence of cyclohexene does not produce a carbene-cyclohexene addition product.

Summary

Ligand-transfer reactions of cyclobutadiene- and π -cyclopentadienyl-metal complexes have been shown to occur quite readily, and often in good yield. Many other organometallic complexes, such as the π -allylmetal complexes or benzene-metal complexes, which have similar bonding between the metal and the ligand, might therefore be expected to undergo ligand-transfer reactions.

The decision to attempt some ligand-transfer reactions of π -allylmetal complexes was made after some early work on the reaction of diiron nonacarbonyl with endoethoxytetraphenylcyclobutenylpalladium chloride (11, R=Ph, R'=Et)

had produced some evidence of a ligand transfer from palladium to iron. Thus the first part of the following work describes some attempts to transfer π -allyl groups from one metal to another, and offers some conclusions on the reactivities of various substituted π -allyliron tricarbonyl chlorides.

The ligand-transfer reactions were usually carried out under heterogeneous conditions, which is also generally the case with the ligand-transfer reactions of cyclobutadiene- and π -cyclopentadienyl-metal complexes. In order to see if homogeneous conditions could lead to further elucidation of the mechanisms of reactions involving organometallic compounds, a number of reactions between a purely organic ligand, phthaloyl chloride, and metal carbonyls such as iron pentacarbonyl and nickel carbonyl, were also studied.

DISCUSSION

DISCUSSION

I. Ligand-transfer reactions

One of the first ligand-transfer reactions to be reported was the reaction of tetraphenylcyclobutadiene-palladium chloride (12, R=Ph, X=Cl) with iron pentacarbonyl in refluxing xylene to give an 88% yield of tetraphenylcyclobutadieneiron tricarbonyl³² (3). Thus the reaction of (12, R=Ph, X=Cl) with diiron nonacarbonyl (this being generally the most reactive of the iron carbonyls) might also be expected to give a good yield of the complex (3). The reaction was first carried out in benzene solution at room temperature for three hours and gave back the starting materials; when carried out in benzene solution at room temperature for 48 hours, the expected complex (3) was obtained, but only in 11% yield. This was raised to 16% by use of tetraphenylcyclobutadienepalladium bromide (15) instead of the chloride (12, R=Ph, X=Cl).

The first step in this reaction is probably complex formation between the diiron nonacarbonyl and the palladium complex. The next step, however, is not certain since there are two main mechanisms by which the reaction may proceed. The first is the possibility of transient formation of free

tetraphenylcyclobutadiene, which then attaches itself to the iron. The second possibility is that the tetraphenylcyclobutadiene does not become completely detached from the metal at any time, but rather that it forms an intermediate in which both metals are attached simultaneously to the ring.

Pettit et al.²⁵ have obtained evidence to show that free cyclobutadiene, obtained by oxidation of its iron tricarbonyl complex with cerium (IV), is capable of existence, even though only for a short time. Free tetraphenylcyclobutadiene, which would be expected to be more stable than cyclobutadiene itself, might also be capable of existing for a short time and might, therefore, be an intermediate in the above reactions.

If, on the other hand, the tetraphenylcyclobutadiene does not become detached from the metal at any time, it might be possible to detect an intermediate containing both metals. For this purpose, the reaction of (15) with diiron nonacarbonyl was tried at 0°C and at -25°C for four hours, taking an infra-red (i.r.) spectrum of the reaction mixture every thirty minutes; all attempts to detect an intermediate were unsuccessful, unchanged reactants being obtained even after four hours. A similar negative result was obtained using iron pentacarbonyl instead of diiron nonacarbonyl.

The complexes (12, R=Ph, X=halogen) arise from reaction of hydrogen halides with both endo-ethoxytetra-

phenylcyclobutenylpalladium chloride (11, P=Ph, R'=Et) and exo-ethoxytetraphenylcyclobutenylpalladium chloride (14).³¹ Attempted transfer of the cyclobutenyl group from (11, R=Ph, R'=Et) and (14) to iron was tried, by reaction of each of the complexes with diiron nonacarbonyl. Ether was found to be the best solvent for these reactions, giving slightly more of the product than hexane. When the reactants were stirred together overnight in ether, both the endo-complex (11, R=Ph, R'=Et) and the exo-complex (14) gave the same products. A yellow solid, containing no trace of either metal, was isolated; it decomposed rapidly at 108°C and gave sharp peaks in its i.r. spectrum (see appendix), but thin layer chromatography (TLC) in cyclohexane gave two spots, which were found to be inseparable by any other means. A molecular weight measurement in benzene of the product from the reaction of the endo-isomer (11, R=Ph, R'=Et) gave 765, whilst the one of the product from the reaction of the exo-isomer (14) gave 818. It is quite probable that the two derivatives obtained in each case are isomers of the same organic compound; this compound is probably a dimer, since the mixture of products analysed for $C_{27}H_{25}O_3$. However, as the product of the reactions was a mixture, no further speculation is possible.

Break-down of the palladium complex in these reactions occurs quite readily, but apparently the second step that would be expected for a ligand-transfer reaction --

that of transfer of the cyclobutenyl group to the iron -- does not occur. However, evidence for the transfer from palladium to iron was observed when reaction of the endo-complex (11, R=Ph, R'=Et) with diiron nonacarbonyl was carried out for only two hours. The product in this case was again a yellow solid, giving the same i.r. spectrum as the product above, except that two very strong peaks were now observed in the metal carbonyl region (see appendix). The melting-point of this product was 97°C, and TLC in cyclohexane gave three spots, two of them identical with those obtained for the organic product above. Again, the compounds could not be separated preparatively. A molecular weight measurement of the mixture in benzene gave 645, and it analysed for $C_{35}H_{29}FeO_5$, but no further speculation is useful at this stage.

Reaction of the exo-complex (14) with diiron nonacarbonyl for only two hours resulted in the same two inseparable (except by TLC) organic derivatives as those previously obtained, with no trace of a metal carbonyl derivative.

Although no definitely characterised products were isolated from the reactions of the cyclobutenyl complexes with diiron nonacarbonyl, the results were interesting enough to suggest that ligand-transfer reactions could profitably be applied to π -allylmetal compounds. Accordingly, a number of π -allylpalladium complexes were prepared, and

reacted with diiron nonacarbonyl in an attempt to transfer π -allyl groups from palladium on to iron.

One of the simplest π -allyl complexes of palladium is π -allylpalladium chloride (26), which has been prepared in high yield⁶² from the reaction of allyl chloride with sodium chloropalladite and carbon monoxide in aqueous methanol. It has been found by D. F. Pollock, working in this laboratory, that use of bis(benzonitrile)palladium dichloride, $(\text{PhCN})_2\text{PdCl}_2$, (prepared by the method of Kharasch⁶⁸) instead of sodium chloropalladite gives even better yields of π -allylpalladium chloride. This latter method was also used to prepare the methyl-substituted allyl derivatives, π -methallylpalladium chloride (30) and π -crotylpalladium chloride (45).

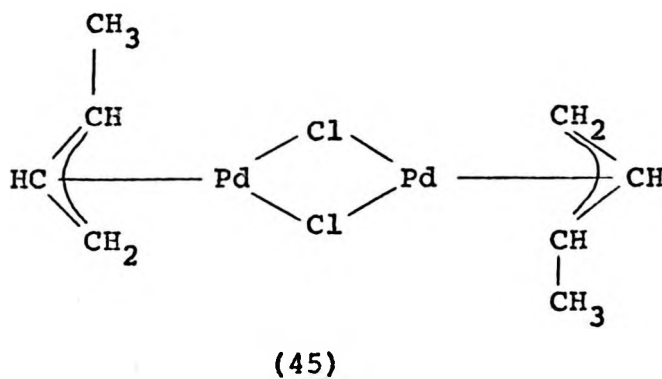

The reactions of these three compounds with diiron nonacarbonyl have produced some interesting results. With π -allylpalladium chloride (26) transfer of the allyl group to the iron took place quite readily to produce π -allyliron tricarbonyl chloride (32, X=Cl) (Eqn. 5).

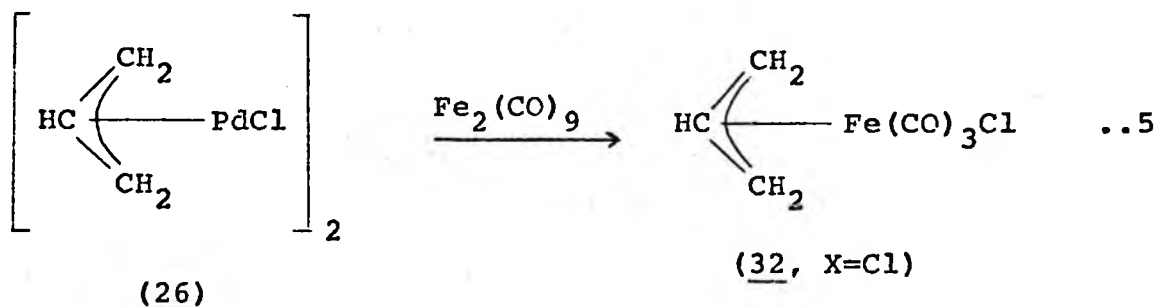

The reaction proceeded in a variety of solvents, the yield obtained being 30% in benzene, 35% in petrol ether, 36% in hexane, and 39% in ether. The previously reported best yield (35%) of (32, X=Cl), by Murdoch and Weiss,⁶⁰ was obtained from the reaction of allyl chloride with diiron nonacarbonyl in hexane.

An attempted ligand-exchange reaction between π -allyliron tricarbonyl chloride and tetraphenylcyclobutadienepalladium chloride (12, R=Ph, X=Cl) was unsuccessful, unchanged reactants being obtained in all cases.

The reaction of π -methallylpalladium chloride (30) with diiron nonacarbonyl produced a red-green gum, from which a red gum sublimed under vacuum at room temperature, leaving behind a dark green solid, which was identified by its i.r. spectrum as triiron dodecacarbonyl. The red gum was identified as π -methallyliron tricarbonyl chloride (34, X=Cl) by comparison of its i.r. spectrum (see appendix) with that obtained for an authentic sample.⁶¹ The red gum could not be crystallised due to the presence of a small amount of an impurity; this was probably some triiron

dodecacarbonyl which, as described later, sublimes slowly under vacuum at room temperature.

The product from the reaction of π -crotylpalladium chloride (45) with diiron nonacarbonyl was obtained as a red gum in the same way, but the yield was so small that nothing could be inferred from the i.r. spectrum.

As methyl-substituted π -allylpalladium complexes were found to give non-crystallisable products when reacted with diiron nonacarbonyl, it was decided to try π -allyl complexes containing a larger substituent, such as a phenyl group, in the hope that crystalline products could be isolated.

π -Phenallylpalladium chloride (46) has previously been prepared⁵⁶ by the reaction of palladium chloride with β -methyl-styrene in 50% acetic acid. The reaction of palladium chloride with allylbenzene (47) should also produce the complex (46), and this has been found to be the case, the reaction proceeding quite readily in benzene solution, although the yield (23%) is less than that previously reported in acetic acid⁵⁶ (42%).

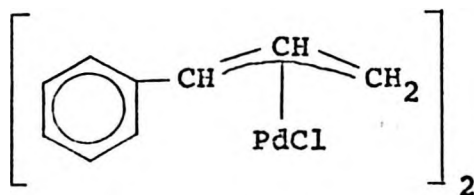

(46)

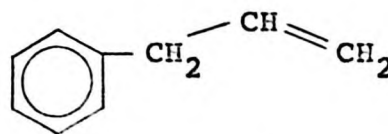

(47)

The i.r. and n.m.r. spectra of (46) are both reported, for the first time, in the appendix. The n.m.r. spectrum shows that the phenyl group in (46) is cis to H₁ (48) rather than trans (49), since the coupling constant for H₄ being split into a doublet by H₁ is 12.2 cycles per second; this is about the normal value for trans-protons in a π-allyl group, whilst the normal value for cis-protons is between 6 and 7 cycles per second.

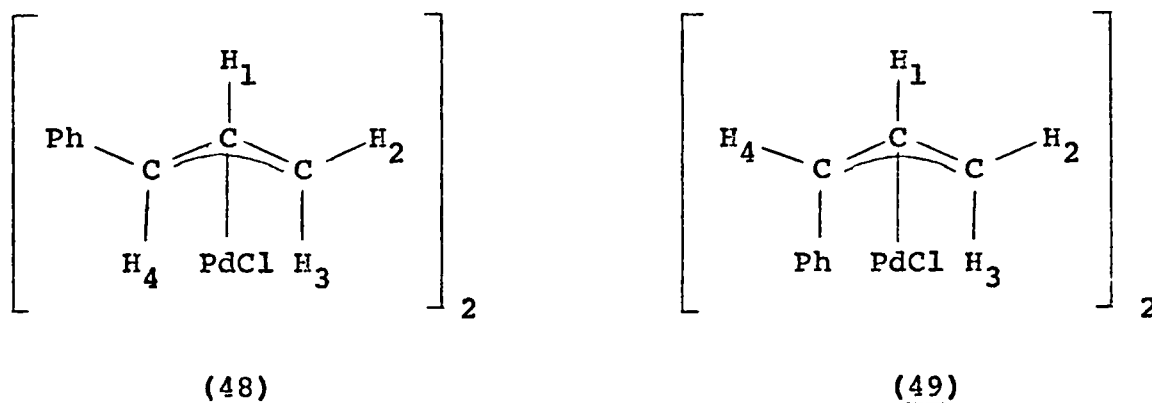

The reaction of (46) with diiron nonacarbonyl produced a red-green gum, from which the dark green triiron dodecacarbonyl sublimed slowly under vacuum at room temperature, leaving behind a red gum which could not be crystallised, probably because all of the triiron dodecacarbonyl could not be removed. The metal carbonyl bands in the i.r. spectrum of the red gum are compared with those in triiron dodecacarbonyl, diiron nonacarbonyl, and π-allyliron tricarbonyl chloride (32, X=Cl) in the following table.

Red gum (liquid film)	Fe ₃ (CO) ₁₂ (KBr disc)	Fe ₂ (CO) ₉ (KBr disc)	←Fe(CO) ₃ Cl (KBr disc)
2083m (cm ⁻¹)	2028w	2083s	2091vs
2041w	1953vs	2020s	2013vs
1992vs	1795m	1832s	1985sh
1938vs	1767m		

w=weak, m=medium, s=strong, vs=very strong, sh=shoulder.

The i.r. spectrum of the red gum is reported in full in the appendix, but without any other evidence it is impossible to decide whether or not the previously unreported π -phenallyliron tricarbonyl chloride (50) has been prepared.

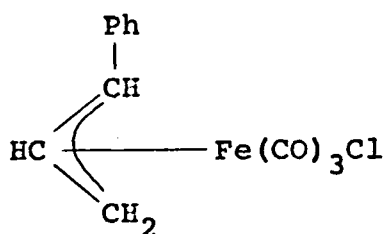

(50)

All of the π -allyl complexes so far described have had purely hydrocarbon allyl groups, but many π -allyl complexes containing other substituents are also readily obtainable. The following three π -allylpalladium complexes were all prepared by methods reported in the literature: di- μ -chlorodi{4-chlorobut-2-enyl}dipalladium(II)⁶⁹ (51, X=Cl), di- μ -chlorodi{4-methoxybut-2-enyl}dipalladium(II)⁵⁷

(51, X=OMe), and di- μ -chlorobis{2,5-dimethylhexa-2,4-dienyl}dipalladium(II)⁵⁷ (52).

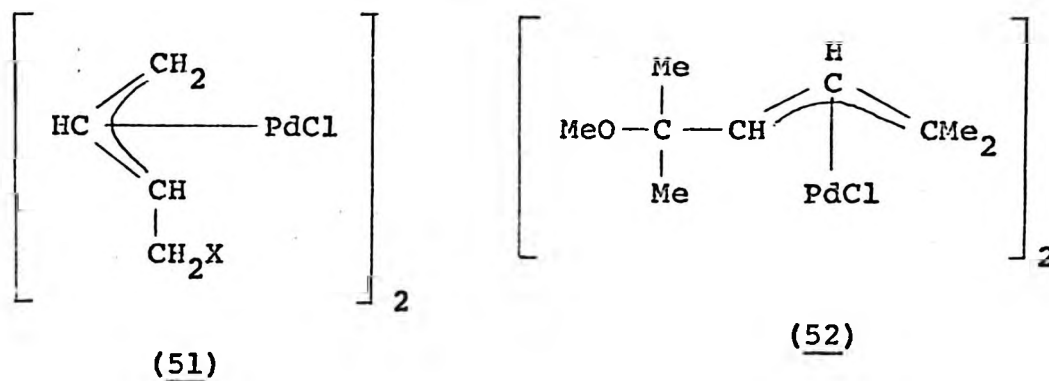

Each of these three compounds was reacted with diiron nonacarbonyl in either hexane or ether, and each of them gave the same decomposition products -- iron pentacarbonyl, triiron dodecacarbonyl and metallic palladium -- along with an unidentified and non-crystallisable oil. Similar results were obtained when iron pentacarbonyl was used instead of diiron nonacarbonyl. Side-reactions probably occur here between the iron and the chlorine or oxygen in the side-chains of the palladium complexes, giving complex mixtures of products.

The main conclusion to be drawn from all these attempted ligand-transfer reactions seems to be that diiron nonacarbonyl is surprisingly poor as a ligand-transfer agent. This may well be due to the temperatures at which these reactions are carried out; above 40°C, diiron nonacarbonyl decomposes very rapidly, so that these reactions are usually carried out at either 40°C or at room temperature. On the

other hand, ligand-transfer reactions with iron pentacarbonyl are usually carried out in refluxing benzene or refluxing xylene, and it seems that these higher temperatures are required in most cases to cause the ligand-transfer to occur.

An excellent example of these ideas is afforded by the reactions of tetraphenylcyclobutadienepalladium chloride (12, R=Ph, X=Cl) with iron pentacarbonyl in refluxing xylene, and with diiron nonacarbonyl in benzene at room temperature. In the first case, an 88% yield of tetraphenylcyclobutadieneiron tricarbonyl (3) was obtained,³² whilst in the second case, the best yield of (3) obtained was only 11%.

Another reason for keeping the temperature below 40°C in the reactions of the π -allyl complexes is that many π -allyl compounds are unstable at higher temperatures.

II. Reactions of organic halides with metal carbonyls

Coffey⁶⁷ has found that iron pentacarbonyl reacts with organic halides if (a) the halide has an activating group such as phenyl, and (b) there are at least two halogens in very close proximity to each other. The readily-available organic compound phthaloyl chloride (53) meets both of these conditions, and it was reacted, under various conditions, with iron pentacarbonyl.

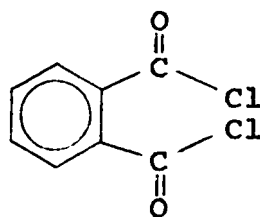

(53)

The reaction was tried in cyclohexane, benzene, petrol ether, tetrahydrofuran, and without any solvent; the same products, in varying amounts, were obtained in all reactions, the major products being inorganic materials and phthalic anhydride. This latter compound probably arose by hydrolysis of phthaloyl chloride, possibly during the work-up procedures since dried solvents were used in all reactions. However, the most interesting product to arise from these reactions was biphthalide (54), the best yield (19%) of this being obtained when no solvent was present.

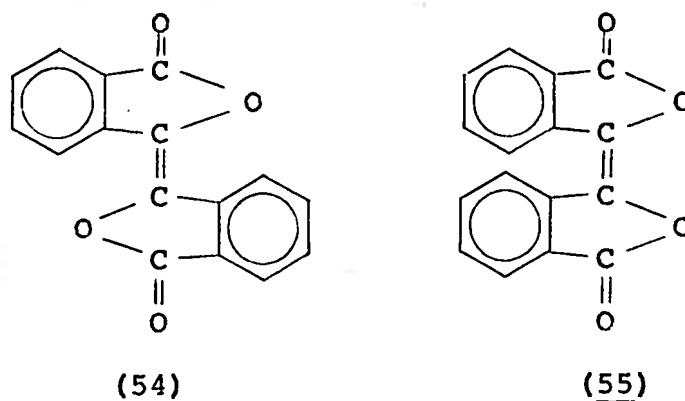

The product was identified by analysis, melting-point and the i.r. spectrum; the latter also showing that the biphthalide obtained was the trans-isomer (54), since the less symmetrical cis-isomer (55) would have absorption around 1667 cm^{-1} for the bridging double bond, and this was not observed. The mechanism of formation of biphthalide in these reactions is discussed later.

Reaction of phthaloyl chloride with diiron nonacarbonyl in the same solvents as above, and also reaction of phthaloyl chloride with disodium iron tetracarbonylate⁷⁰ in either tetrahydrofuran or ether, yielded inseparable mixtures in every case. However, reaction of phthaloyl chloride with nickel carbonyl led to the formation of biphthalide, the best yield (16%) being obtained in tetrahydrofuran. Phthalic anhydride was only produced in sparing amounts in cyclohexane, cyclohexene and petrol ether, and not at all in tetrahydrofuran, carbon tetrachloride or benzene. Apart from nickel chloride and nickel metal, the other product, or mixture of products, in these reactions was a non-crystallisable yellow oil.

The biphthalide produced in these reactions probably arises either via a carbene intermediate such as (56), or via a metal complex, such as those described later.

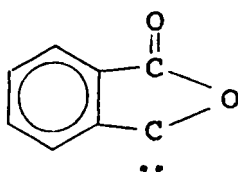

(56)

An intermediate such as (56) could form biphthalide easily by dimerisation, and it has been proposed by Ramirez *et al.*⁷¹ to occur in the preparation of biphthalide from phthalic anhydride and triethyl phosphite; it has also been proposed to occur in the preparation of biphthalide by

photodimerisation of benzocyclobutenedione.⁷²

If a free carbene intermediate is produced in these reactions, it should be possible to trap it with a compound containing a double- or triple-bond. However, all attempts to do this, either with cyclohexene or diphenylacetylene, were unsuccessful, suggesting that a free carbene is not produced in the reactions.

Another possible intermediate in the production of biphthalide in these reactions is a metal complex, which could be one of two kinds. The preparation⁷³ of such compounds as (57) ($R=R'=H, Me, Et, Ph$ or $R=H, R'=Me, Et, Bu, Ph$) from oxidation of (58) in acidic media, and (59) from a Diels-Alder reaction of (57) ($R=R'=H$) with cyclopentadiene, seem to suggest that a structure such as (60) ($M=Ni$ or Fe) is plausible for the intermediate in the reactions of phthaloyl chloride with either nickel carbonyl or iron pentacarbonyl.

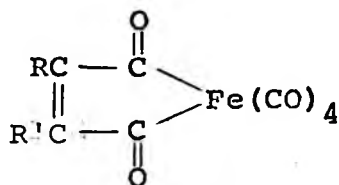

(57)

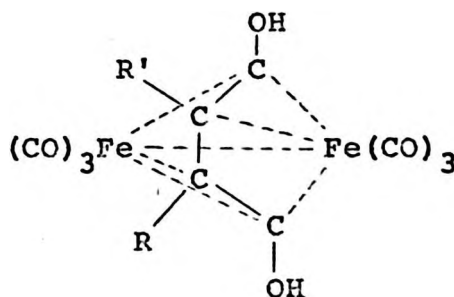

(58)

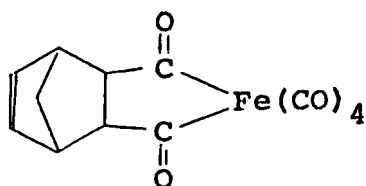

(59)

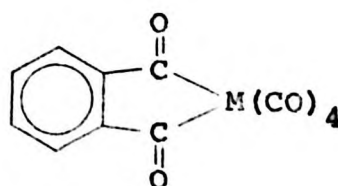

(60)

Many other examples of compounds which form such heterocyclic five-membered rings with a transition metal have been described in the literature.⁷⁴ However, another possibility for a metal complex as intermediate in the reactions of phthaloyl chloride with nickel carbonyl and iron pentacarbonyl is the complex (61, M=Fe or Ni).

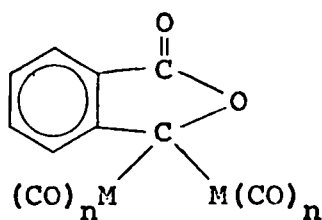

This is very similar to the structure found (62)⁷⁵ for the compound of empirical formula $\text{Co}_2(\text{CO})_9 \cdot \text{HC}\equiv\text{CH}$, prepared⁷⁶ by treating dicobalt octacarbonyl with acetylene at elevated temperature and pressure.

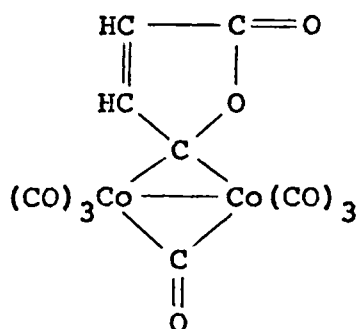

It has also been found⁷⁷ that by treating acetylene in methanol with carbon monoxide in the presence of dicobalt

octacarbonyl, the compound (63) is obtained, and this can reasonably be supposed to arise via the intermediate (62). In similar fashion, biphthalide could be imagined to arise via the intermediate (61).

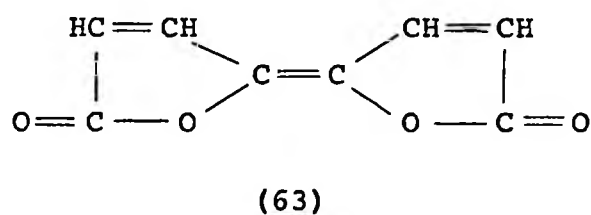

The reactions of phthaloyl chloride with various other reagents were investigated, in the hope of improving the yield of biphthalide, but the yields obtained were still low.

The preparation of a highly active zinc/copper couple⁷⁸ has proved extremely useful in the preparation of cyclopropanes from olefins and either diiodomethane or dibromomethane. Such a zinc/copper couple was refluxed with phthaloyl chloride in benzene, cyclohexane or ether; the best yield of biphthalide (14%) was obtained in benzene. The other product of the reaction was a non-crystallisable brown oil.

The preparations of di[1,2-bis(diphenylphosphino)ethane]nickel (64, M=Ni) and di[1,2-bis(diphenylphosphino)ethane]palladium (64, M=Pd) have been described by Chatt *et al.*⁷⁹ In both of these complexes the metal is in the zerovalent state, thus these compounds should react readily

with a halogen-containing compound such as phthaloyl chloride.

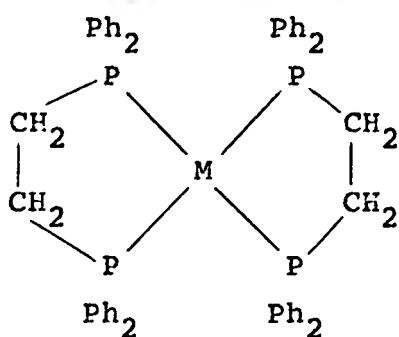

(64)

Reaction of (64, M=Ni) with phthaloyl chloride gave a very small yield of biphthalide, the major product being ethane-1,2-bis(diphenylphosphine oxide) (65).

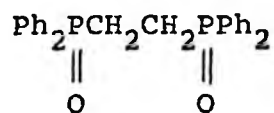

(65)

Reaction of (64, M=Pd) with phthaloyl chloride led to a 9% yield of biphthalide and a 37% yield of [1,2-bis(diphenylphosphino)ethane]palladium dichloride (66).

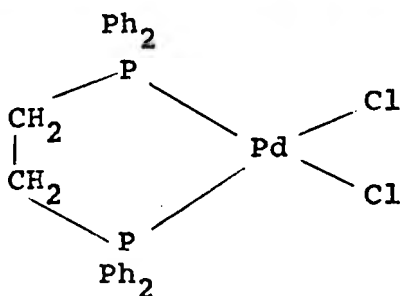

(66)

Finally, the reaction of benzoyl chloride, PhCOCl , rather than phthaloyl chloride, with diiron nonacarbonyl and iron pentacarbonyl, was studied. In all cases the same red oil was obtained, showing metal carbonyl peaks in its i.r. spectrum identical with those in iron pentacarbonyl;⁸⁰ the oil was found to be non-crystallisable.

EXPERIMENTAL

EXPERIMENTAL

Experimental Procedures

Melting-points

These were determined using a Thomas Hoover capillary melting-point apparatus, and are uncorrected. Melting-points of all organometallic compounds were measured in sealed capillaries evacuated to about 20mm. pressure.

Molecular weight measurements

These were made on a vapour pressure osmometer (Mechrolab Inc.).

Infra-red spectra

These were recorded as potassium bromide discs (unless otherwise stated) on a Beckmann IR5 spectrometer.

Nuclear magnetic resonance spectra

These were run in deuteriochloroform on a Varian A60 60 M/c spectrometer.

Reagents

The petroleum ether used was the fraction b.pt. 30-60°C. Tetrahydrofuran was freshly distilled from lithium aluminium hydride; ether was freshly distilled and sodium-dried; benzene and cyclohexane were both sodium-dried; methylene

chloride and chloroform were both dried over anhydrous sodium sulphate. Chromatography columns were made up of silica gel (Fisher Scientific Co. 28-200 Mesh) or Florisil (Fisher Scientific Co. 60-100 Mesh). Thin layer chromatography was carried out on silica gel G (E. Merck AG, Darmstadt, Germany). All reactions involving organometallic compounds were carried out under an atmosphere of nitrogen.

I. Ligand-transfer reactions

Tetraphenylcyclobutadieneiron tricarbonyl (3)

Tetraphenylcyclobutadienepalladium bromide⁸¹

(1.13 gms., 0.0018 moles) and diiron nonacarbonyl (0.66 gms., 0.0018 moles) were stirred for 48 hours at room temperature in benzene. The dark brown precipitate was filtered off and shown to be a mixture of palladium and iron salts. Removal of solvent from the filtrate gave tetraphenylcyclobutadieneiron tricarbonyl as a yellow solid (0.147 gms., 16%) m.pt. 230-231°C (Lit.¹¹ 234°C). The i.r. spectrum was identical with that reported in the literature.¹¹

Reactions of tetraphenylcyclobutadienepalladium bromide⁸¹

(15) with diiron nonacarbonyl at low temperatures

The reactions were carried out, using the same amounts of reactants as above, in an ice-bath at 0°C, and in a carbon tetrachloride slush bath at -25°C. The solvent used was ether, and a small amount of the solution was removed every thirty minutes, filtered to remove any solid,

and an i.r. spectrum taken of the liquid. Even after four hours, the same i.r. spectrum was being obtained, and was identical to that of the starting complex (15).

Reactions of endo-ethoxytetraphenylcyclobutenylpalladium chloride⁸¹ (11, R=Ph, R'=Et) with diiron nonacarbonyl

(a) The complex (11, R=Ph, R'=Et) (1.3 gms., 0.0024 moles) and diiron nonacarbonyl (0.87 gms., 0.0024 moles) were stirred for two hours in ether at room temperature. The metallic palladium formed was filtered off, and removal of solvent from the filtrate gave a green solid, soluble in petrol ether, from which it was re-precipitated as a yellow-green solid at -78°C . Further recrystallisation from petrol ether at -78°C yielded yellow crystals m.pt. 97°C (decomp.). The i.r. spectrum showed absorption in the metal carbonyl region and is reported in the appendix. TLC in cyclohexane gave three different spots, but the mixture could not be separated preparatively. The yellow compound analysed for C 70.97%, H 4.76%, Fe 9.84%, and the molecular weight in benzene was determined to be 645.

(b) Using the same amounts as above, the complex (11, R=Ph, R'=Et) and diiron nonacarbonyl were stirred together overnight in ether at room temperature. The product was isolated, in similar fashion to the previous reaction, as a yellow solid m.pt. 109°C (decomp.). The i.r. spectrum showed no absorption in the metal carbonyl region, and is reported in the appendix. TLC in cyclohexane gave two

different spots, but again the mixture could not be separated preparatively. The yellow compound analysed for C 82.06%, H 6.15%, and the molecular weight in benzene was determined to be 765. The analysis gave the composition $C_{27}H_{25}O_3$ for the product.

Reactions of exo-ethoxytetraphenylcyclobutenylpalladium chloride³¹ (14) with diiron nonacarbonyl

(a) The complex (14) and diiron nonacarbonyl, in the same amounts as the reactants above, were stirred in ether at room temperature for two hours. The product was isolated, in similar fashion to those above, as a yellow solid m.pt. $108^{\circ}C$ (decomp.). Its i.r. spectrum was identical to that obtained for the product of reaction (b) above. TLC in cyclohexane gave two spots, but again the mixture could not be separated preparatively.

(b) The reaction was repeated for a longer length of time (overnight) and gave a yellow solid m.pt. $108^{\circ}C$ (decomp.), with an i.r. spectrum identical to that obtained in the previous reaction. TLC in cyclohexane gave two spots, and again the mixture could not be separated preparatively. A mixed melting-point of this product with that from reaction (b) above, gave $108^{\circ}C$ (decomp.). A molecular weight determination in benzene gave 818, similar to the value obtained (765) for the product of reaction (b) above.

π -Allylpalladium chloride (26)

Bis(benzonitrile)palladium dichloride⁶⁸ (5gms., 0.013

moles) was dissolved in 200 mls. methanol, then allyl chloride (5 gms., 0.065 moles) and 5 mls. water were added. Carbon monoxide was bubbled through the solution for 25 minutes, and the resulting yellow suspension poured into 500 mls. water, which was then extracted repeatedly with 150 ml. portions of chloroform. The yellow chloroform extracts were combined and dried over anhydrous sodium sulphate for three hours. Removal of solvent yielded π -allylpalladium chloride as yellow crystals (2.2 gms., 93%) m.pt. 157-158°C (decomp.) [Lit.⁶² 158°C (decomp.)]; mixed melting-point with an authentic sample,⁶² 156-157°C (decomp.). The i.r. spectrum was identical with that reported in the literature.⁶²

π -Methallylpalladium chloride (30)

This was prepared in 74% yield in an analogous manner to the above, substituting methallyl chloride for allyl chloride. The product was obtained as yellow crystals m.pt. 165-168°C (decomp.) [Lit.⁶² 166-168°C (decomp.)]. The i.r. spectrum was identical with that reported in the literature.⁶²

π -Crotylpalladium chloride (45)

This was prepared in 65% yield in an analogous manner to the above, substituting crotyl chloride for allyl chloride. The product was obtained as yellow crystals m.pt. 138-139°C (decomp.) [Lit.⁶² 136-137°C (decomp.)]. The i.r. spectrum was identical with that reported in the literature.⁶²

π -Phenallylpalladium chloride (46)

Bis(benzonitrile)palladium dichloride (5 gms., 0.013 moles) and allylbenzene (6 gms., 0.052 moles) were refluxed overnight in benzene. The black residue was filtered off, and the dark brown filtrate collected. The residue was washed with benzene, until the washings being collected were colourless; the combined washings were then added to the filtrate, and the solvent removed to leave a dark brown residue, which was dissolved in methylene chloride, filtered, and the filtrate chromatographed on a Florisil column. A brown fraction was eluted in methylene chloride, and the solvent was removed to leave a brown solid. This was recrystallised twice from benzene -- petrol ether (1:1) to yield π -phenallylpalladium chloride as yellow crystals (0.78 gms., 23%) m.pt. 196-199°C (Lit.⁵⁶ 195-200°C) Found: Pd 41.77%, C_9H_9PdCl requires Pd 41.13%. The i.r. and n.m.r. spectra are reported in the appendix.

 π -Allyliron tricarbonyl chloride (32, X=Cl)

π -Allylpalladium chloride (0.5 gms., 0.0027 moles) and diiron nonacarbonyl (0.995 gms., 0.0027 moles) were stirred overnight in ether at room temperature. The metallic palladium formed was filtered off, and removal of solvent from the filtrate gave a green residue, soluble in petrol ether, from which it was re-precipitated as yellow-green crystals upon cooling to -78°C. Two further recrystallisations from petrol ether at -78°C yield π -allyliron tricarbonyl

chloride as a yellow solid (0.114 gms., 39%) m.pt. 86-89°C (Lit.⁶⁰ 88-89°C); mixed melting-point with an authentic sample,⁶⁰ 86-89°C. The i.r. spectrum was identical with that reported in the literature.⁶⁰

Reaction of π -allyliron tricarbonyl chloride with tetraphenylcyclobutadienepalladium chloride (12, R=Ph, X=Cl)

Reaction was carried out with a 1:1 mole ratio of reactants, in refluxing benzene for three hours, and unchanged reactants were obtained. Analogous negative results were obtained when the reactants were refluxed in benzene for 48 hours.

π -Methallyliron tricarbonyl chloride (34, X=Cl)

π -Methallylpalladium chloride (0.5 gms., 0.0017 moles) and diiron nonacarbonyl (1.86 gms., 0.0051 moles) were stirred overnight in hexane at room temperature. The metallic palladium formed was filtered off, and removal of solvent from the filtrate gave a red-green residue. This was vacuum-sublimed at room temperature, and a red gum rapidly sublimed on to the cold finger, leaving most of the dark green triiron dodecacarbonyl (identified by its i.r. spectrum) behind. The red gum could not be crystallised, but gave an i.r. spectrum (liquid film -- reported in the appendix) identical to the one obtained for an authentic sample⁶¹ of π -methallyliron tricarbonyl chloride. TLC of the product in benzene-petrol ether (1:3) gave only one spot, which had the same R_f value as that obtained for the authentic sample.

Reaction of π -crotylpalladium chloride (45) with diiron nonacarbonyl

This was carried out in exactly the same manner as the previous reaction, but gave so small a yield of product that nothing could be inferred from the i.r. spectrum.

Reaction of π -phenallylpalladium chloride (46) with diiron nonacarbonyl

π -Phenallylpalladium chloride (0.5 gms., 0.0019 moles) and diiron nonacarbonyl (0.7 gms., 0.0019 moles) were stirred overnight in hexane at room temperature. The metallic palladium formed was filtered off, and removal of solvent from the filtrate gave a red-green residue. This was vacuum-sublimed at room temperature, and the dark green triiron dodecacarbonyl (identified by its i.r. spectrum) sublimed slowly on to the cold finger, leaving a red gum which it was found impossible to crystallise. The i.r. spectrum (liquid film) of the red gum is reported in the appendix.

Reactions of diiron nonacarbonyl or iron pentacarbonyl with di- μ -chlorodi{4-chlorobut-2-enyl}dipalladium (II)⁶⁹ (51, X=Cl), di- μ -chlorodi{4-methoxybut-2-enyl}dipalladium (II)⁵⁷ (51, X=OMe), di- μ -chlorobis{2,5-dimethylhexa-2,4-dienyl}dipalladium (II)⁵⁷ (52)

All of these reactions were carried out in the same manner as each other in either hexane or ether, and all gave

the same decomposition products along with an unidentified oil, thus only one reaction is described as an example.

The complex (51, X=Cl) (0.6 gms., 0.0026 moles) and diiron nonacarbonyl (1.42 gms., 0.0039 moles) were stirred overnight in hexane at room temperature. The black residue was filtered off, and a dark brown material washed out from it in acetone, leaving metallic palladium. Removal of solvent from the dark brown solution gave a brown oil, which was completely non-crystallisable. Removal of solvent from the original filtrate gave a green residue, soluble in petrol ether, from which it was re-precipitated as a dark green solid upon cooling to -78°C . Its i.r. spectrum showed it to be triiron dodecacarbonyl.

II. Reactions of organic halides with metal carbonyls

Reactions of phthaloyl chloride (53) with iron pentacarbonyl

The reaction with no solvent present, which gave the best yield of biphthalide, is described.

Phthaloyl chloride (4.06 gms., 0.02 moles) and iron pentacarbonyl (3.92 gms., 0.02 moles) were stirred together overnight at 60°C , and a dark green solid mass was obtained; it was digested for one hour with 200 mls. boiling chloroform, then the remaining dark green solid was filtered off and shown to be a mixture of iron salts. The dark orange filtrate was chromatographed on a silica gel column; a deep yellow solution was eluted in benzene, and pale yellow

solutions in ether and ethanol. Removal of solvent from the ether fraction gave phthalic anhydride (0.98 gms., 33%) m.pt. 128-130°C (authentic sample 130-131°C). The i.r. spectrum was identical to that for the authentic sample. Removal of solvent from the ethanol fraction gave a very small yield of o-phthalic acid m.pt. 203-206°C (authentic sample 205-208°C). The i.r. spectrum was identical to that for the authentic sample. Removal of solvent from the benzene fraction, and recrystallisation of the yellow solid from chloroform gave biphthalide (1 gm., 19%) m.pt. 337-338°C (Lit.⁸² 335°C). Found: C 72.72%, H 3.35%, $C_{16}H_8O_4$ requires C 72.73%, H.3.05%. A mixed melting-point with an authentic sample⁷¹ gave 337-339°C; the i.r. spectrum was identical to that reported in the literature.⁸³

Reactions of phthaloyl chloride with diiron nonacarbonyl

In all cases, inseparable mixtures were obtained.

Reactions of phthaloyl chloride with iron tetracarbonylate dianion

In all cases, inseparable mixtures were obtained.

Reactions of phthaloyl chloride with nickel carbonyl

The reaction in tetrahydrofuran, with a mole ratio of 2:1 of nickel carbonyl: phthaloyl chloride, in which the best yield of biphthalide was obtained, is described.

Phthaloyl chloride (2.03 gms., 0.01 moles) and nickel carbonyl (3.4 gms., 0.02 moles) were stirred at room temperature for one hour in 25 mls. tetrahydrofuran, during which

time a pale yellow solution formed. It was then warmed slowly until gently refluxing, the colour darkening all the while through orange to red; heating was continued until the solution was at the reflux temperature of the solvent. A dark brown precipitate formed, which was filtered off, and removal of the solvent from the filtrate gave a yellow oil, which proved to be non-crystallisable. The dark brown residue was digested for one hour with 100 mls. boiling chloroform, then the remaining dark brown solid was filtered off and shown to be a mixture of nickel chloride and nickel metal. Removal of solvent from the yellow filtrate gave a yellow solid, which upon recrystallisation from chloroform yielded biphthalide (0.42 gms., 16%) m.pt. 340-342°C; mixed melting-point with an authentic sample,⁷¹ 339-342°C. The i.r. spectrum was identical to that reported in the literature.⁸³

Reactions of phthaloyl chloride with nickel carbonyl in the presence of cyclohexene or diphenylacetylene

A 2:2:1 mole ratio of nickel carbonyl:cyclohexene or diphenylacetylene:phthaloyl chloride was used, in carbon tetrachloride, and the reactions were carried out in the same manner as the previous reaction. Essentially the same results were obtained, the only differences being that the non-crystallisable oil obtained was brown rather than yellow, and the yield of biphthalide was reduced to approximately 9%.

Reactions of phthaloyl chloride with a zinc/copper couple⁷⁸

Phthaloyl chloride (4.06 gms., 0.02 moles) and a zinc/copper couple (4 gms., 0.025 moles) were refluxed overnight in benzene. The dark brown residue was filtered off, and removal of solvent from the filtrate gave a brown oil, which was re-dissolved in benzene and chromatographed on a silica gel column. Two fractions were eluted, one with benzene, and one with ether; removal of solvent from the ether fraction gave a brown oil, which proved to be non-crystallisable. Removal of solvent from the benzene fraction gave biphthalide m.pt. 343-345°C; the i.r. spectrum was identical to that reported in the literature.⁸³ The original dark brown residue was digested with 200 mls. boiling chloroform for one hour, then filtered. Removal of solvent from the filtrate gave more biphthalide m.pt. 340-343°C; the i.r. spectrum was identical to that reported in the literature.⁸³ Total yield of biphthalide = 0.74 gms., 14%.

Reactions of phthaloyl chloride with di [1,2-bis(diphenylphosphino)ethane]nickel⁷⁹ (64, M=Ni)

The complex (64, M=Ni) (1 gm., 0.0012 moles) was dissolved in 50 mls. warm benzene, and the solution then cooled to room temperature. Phthaloyl chloride (0.24 gms., 0.0012 moles) was added slowly, and the mixture stirred for two hours at room temperature. The brown residue was

filtered off, and shown to be a mixture of nickel salts. Removal of solvent from the filtrate gave a yellow mixture of solids, which was dissolved in chloroform. Upon slow evaporation of the solvent, a white solid precipitated out and was filtered off. It was shown to be ethane-1,2-bis-(diphenylphosphine oxide) (65) from its m.pt. 267-270°C (lit. 269-270°C,⁸⁴ 273-275°C⁸⁵). Removal of solvent from the remainder of the filtrate gave mainly biphthalide (shown by its i.r. spectrum) but still with some of the phosphine oxide present; it was not found possible to separate them completely.

Reactions of phthaloyl chloride with di[1,2-bis(diphenylphosphino)ethane]palladium⁷⁹ (64, M=Pd)

The complex (64, M=Pd) (1 gm., 0.0011 moles) and phthaloyl chloride (0.22 gms., 0.0011 moles) were stirred in 50 mls. benzene at room temperature for two hours. The white precipitate was filtered off, and found to be partially soluble in hot water; this soluble portion was shown to be a mixture of palladium salts. The remainder of the precipitate was dried under vacuum and gave [1,2-bis(diphenylphosphino)ethane]palladium dichloride (66) (0.24 gms., 37%). Its i.r. spectrum was identical to that obtained for an authentic sample.⁷⁹ Removal of solvent from the original filtrate gave a yellow solid, which was dissolved in chloroform; the solvent was slowly evaporated off, and yellow crystals of biphthalide (0.03 gms., 9%) precipitated out and were filtered

off. The crystals gave m.pt. 339-341°C, and an i.r. spectrum identical to that reported in the literature.⁸³ Removal of solvent from the remaining pale yellow filtrate gave an inseparable mixture of what appeared, from its i.r. spectrum, to be more biphthalide and an unidentified compound.

Reactions of benzoyl chloride with iron carbonyls

The reaction of benzoyl chloride with diiron nonacarbonyl is described; the reaction with iron pentacarbonyl yielding the same results.

Benzoyl chloride (0.5 gms., 0.0036 moles) and diiron nonacarbonyl (1.3 gms., 0.0036 moles) were stirred overnight in 30 mls. benzene at room temperature. The brown residue was filtered off, and shown to be a mixture of iron salts. Removal of solvent from the filtrate gave a red oil, which was dissolved in petrol ether and chromatographed on a Florisil column; the red compound was eluted in petrol ether-benzene (1:1), and the solvent was removed to leave a red oil, which could not be crystallised. Its i.r. spectrum (liquid film) showed metal carbonyl peaks identical with those in iron pentacarbonyl.⁸⁰

APPENDIX

Infra-red maxima for the product of (a) the reaction between endo-ethoxytetraphenylcyclobutenylpalladium chloride (11, R=Ph, R'=Et) and diiron nonacarbonyl for two hours, (b) the reaction between (11, R=Ph, R'=Et) and diiron nonacarbonyl overnight, or the reaction between exo-ethoxytetraphenylcyclobutenylpalladium chloride (14) and diiron nonacarbonyl either overnight or for two hours.

<u>(a) cm⁻¹</u>	<u>(b) cm⁻¹</u>
3067w	3077w
2994vw	3003vw
2049vs	---
2033vs	---
1880w	---
1835w	---
---	1757vw
1667w	1667w
1600m	1603m
1493m	1493m
1447m	1447m
1389w	1391w
1255m	1253m
1111m	1114m
1074m	1075m
1030m	1032m
915w	917w
761m	761m
694s	694s

vw = very weak w = weak

m = medium s = strong

vs = very strong

Infra-red maxima (cm^{-1}) for π -phenallylpalladium chloride (46).

3067m
2941sh
1517w
1493s
1460w
1433s
1387w
1282w
1182m
1075m
1030w
972m
950w
874m
818w
756vs
690vs

w = weak
m = medium
s = strong
vs = very strong
sh = shoulder

Nuclear magnetic resonance spectrum of π -phenallyl-palladium chloride (46).

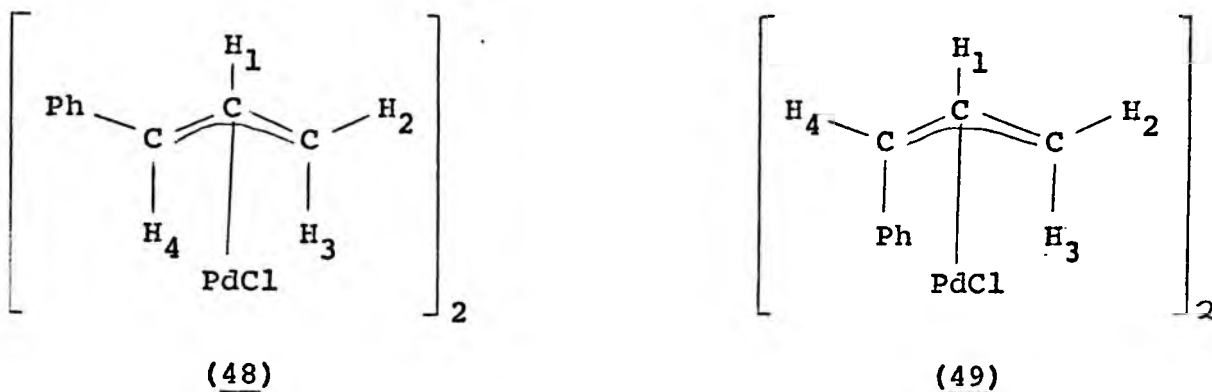

From theoretical considerations, the spectrum expected for the complex (48) would be the following: H_3 to be split by H_1 into a doublet with a coupling constant of about 12 cycles per second (c.p.s.) (usually found for trans-protons in a π -allyl group); H_2 to be split by H_1 into a doublet with a coupling constant of between 6 and 7 c.p.s. (usually found for cis-protons in a π -allyl group); H_1 to be split by both H_3 and H_4 , to a lesser extent by H_2 , and also possibly by the phenyl protons, into a multiplet; H_4 to be split by H_1 into a doublet with a coupling constant of about 12 c.p.s.

For the complex (49), the following spectrum would be expected: H_3 and H_2 to be split into doublets as above; H_1 to be split by H_3 , to a lesser extent by H_2 and H_4 , and also possibly by the phenyl protons, into a multiplet; H_4 to be split by H_1 into a doublet with a coupling constant of between 6 and 7 c.p.s.

The actual spectrum obtained is summarised in the following table:-

<u>T values</u>	<u>Relative Intensities</u>	<u>Assignment</u>	<u>Coupling Constants (c.p.s.)</u>
6.96 (d)	1	H ₃	J ₁₃ = 12.5
6.05 (d)	1	H ₂	J ₁₂ = 6.4
5.39 (d)	1	H ₄	J ₁₄ = 12.2
4.18 (m)	1	H ₁	---
2.68 (m)	5	Ph	---

d = doublet, m = multiplet

The multiplet at 2.68T is typical of phenyl protons, and the multiplet at 4.18T must be assigned to H₁. Only one doublet is obtained with a coupling constant in the region of that for cis-protons, and thus the doublet at 6.05T must be assigned to H₂. This also means that the complex (48) must have been prepared, rather than the complex (49). The doublet at 5.39T is assigned to H₄, and that at 6.96T to H₃.

Infra-red maxima (cm^{-1}) for π -methallyliron
tricarbonyl chloride (34, X=Cl).

2941m
2101s
2028vs
1969vs
1681w
1618m
1447m
1376m
1110w
1029w
887m
847w

w = weak

m = medium

s = strong

vs = very strong

Infra-red maxima (cm^{-1}) for the product of the reaction between π -phenallylpalladium chloride (46) and diiron nonacarbonyl.

3040m
2976m
2083m
2041w
1992vs
1938vs
1592m
1488m
1445w
963m
909w
865w
754m
690s

w = weak

m = medium

s = strong

vs = very strong

BIBLIOGRAPHY

BIBLIOGRAPHY

1. J. A. Wunderlich and D. P. Mellor, *Acta Cryst.* 7, 130 (1954).
2. J. A. Wunderlich and D. P. Mellor, *Acta Cryst.* 8, 57 (1955).
3. J. R. Holden and N. C. Baenziger, *J. Am. Chem. Soc.* 77, 4987 (1955).
4. H. Reihlen, A. Gruhl, G. v. Hessling and O. Pfrengele, *Ann.* 482, 161 (1930).
5. B. F. Hallam and P. L. Pauson, *J. Chem. Soc.* 642 (1958).
6. J. S. Dewar, *Bull. Soc. chim. Fr.* 18, C71 (1951).
7. J. Chatt and L. A. Duncanson, *J. Chem. Soc.* 2939 (1953).
8. H. Dietrich and R. Uttech, *Naturwissen.* 50, 613 (1963).
9. H. Dietrich and R. Uttech, *Z. Kristallogr.* 122, 60 (1965).
10. H. C. Longuet-Higgins and L. E. Orgel, *J. Chem. Soc.* 1969 (1956).
11. W. Hubel and E. H. Braye, *J. Inorg. Nucl. Chem.* 10, 250 (1959).
12. R. P. Dodge and V. Schomaker, *Nature* 186, 798 (1960).
13. R. P. Dodge and V. Schomaker, *Acta Cryst.* 18, 614 (1965).
14. T. J. Kealy and P. L. Pauson, *Nature* 168, 1039 (1951).
15. S. A. Miller, J. A. Tebboth and J. F. Tremaine, *J. Chem. Soc.* 632 (1952).
16. G. Wilkinson, M. Rosenblum, M. C. Whiting and R. B. Woodward, *J. Am. Chem. Soc.* 74, 2125 (1952).
17. P. F. Eiland and R. Pepinsky, *J. Am. Chem. Soc.* 74, 4971 (1952).

18. W. Pfab and E. O. Fischer, *Z. Anorg. Chem.* 274, 316 (1953).
19. J. D. Dunitz and L. E. Orgel, *Nature* 171, 121 (1953).
20. J. D. Dunitz, L. E. Orgel and A. Rich, *Acta Cryst.* 9, 373 (1956).
21. E. O. Fischer and W. Hafner, *Z. Naturforsch.* 10b, 665 (1955).
22. R. B. King and F. G. A. Stone, *J. Am. Chem. Soc.* 81, 5263 (1959).
23. B. Dickens and W. N. Lipscomb, *J. Am. Chem. Soc.* 83, 4862 (1961).
24. B. Dickens and W. N. Lipscomb, *J. Chem. Phys.* 37, 2084 (1962).
25. L. Watts, J. D. Fitzpatrick and R. Pettit, *J. Am. Chem. Soc.* 87, 3253 (1965).
26. G. D. Burt and R. Pettit, *Chem. Comm.* 517 (1965).
27. J. C. Barborak, L. Watts and R. Pettit, *J. Am. Chem. Soc.* 88, 1328 (1966).
28. G. F. Emerson, L. Watts and R. Pettit, *J. Am. Chem. Soc.* 87, 131 (1965).
29. L. Malatesta, G. Santarella, L. Vallarino and F. Zingales, *Angew. Chem.* 72, 34 (1960).
30. L. F. Dahl and W. E. Oberhansli, *Inorg. Chem.* 4, 629 (1965).
31. A. T. Blomquist and P. M. Maitlis, *J. Am. Chem. Soc.* 84, 2329 (1962).
32. P. M. Maitlis and M. L. Games, *J. Am. Chem. Soc.* 85, 1887 (1963).
33. P. M. Maitlis and M. L. Games, *Chem. Ind.* 1624 (1963).
34. P. M. Maitlis and A. Efraty, *J. Organometal. Chem.* 4, 172 (1965).
35. P. M. Maitlis and A. Efraty, *J. Organometal. Chem.* 4, 175 (1965).

36. P. M. Maitlis, A. Efraty and M. L. Games, *J. Organometal. Chem.* 2, 284 (1964).
37. P. M. Maitlis, A. Efraty and M. L. Games, *J. Am. Chem. Soc.* 87, 719 (1965).
38. P. M. Maitlis, *Adv. Organometal. Chem.* 4, 109 (1966).
39. H. D. Kaesz, R. B. King and F. G. A. Stone, *Z. Naturforsch.* 15b, 763 (1960).
40. W. R. McClellan, H. H. Hoehn, H. N. Cripps, E. L. Muetterties and B. W. Howk, *J. Am. Chem. Soc.* 83, 1601 (1961).
41. H. D. Kaesz, R. B. King and F. G. A. Stone, *Z. Naturforsch.* 15b, 682 (1960).
42. J. E. Nordlander and J. D. Roberts, *J. Am. Chem. Soc.* 81, 1769 (1959).
43. H. B. Jonassen, R. I. Stearns, J. Kenttamaa, D. W. Moore and A. G. Whittaker, *J. Am. Chem. Soc.* 80, 2586 (1958).
44. J. Smidt and W. Hafner, *Angew. Chem.* 71, 284 (1959).
45. R. Hüttel and J. Kratzer, *Angew. Chem.* 71, 456 (1959).
46. R. F. Heck and D. S. Breslow, *J. Am. Chem. Soc.* 82, 750 (1960).
47. H. C. Dehm and J. C. W. Chien, *J. Am. Chem. Soc.* 82, 4429 (1960).
48. J. M. Rowe, *Proc. Chem. Soc.* 66 (1962).
49. W. E. Oberhansli and L. F. Dahl, *J. Organometal. Chem.* 3, 43 (1965).
50. A. E. Smith, *Acta Cryst.* 18, 331 (1965).
51. E. J. Lanpher, *J. Am. Chem. Soc.* 79, 5578 (1957).
52. J. Powell, S. D. Robinson and B. L. Shaw, *Chem. Comm.* 78, (1965).
53. R. Mason and D. R. Russell, *Chem. Comm.* 26 (1966).
54. J. K. Becconsall and S. O'Brien, *Chem. Comm.* 302 (1966).

55. G. Wilke, B. Bogdanovic, P. Hardt, P. Heinbach, W. Keim, W. Oberkirch, K. Tanaka, E. Steinrücke, D. Walter and H. Zimmermann, *Angew. Chem. (int. Ed.)* 5, 151 (1966).
56. R. Hüttel, J. Kratzer and M. Bechter, *Chem. Ber.* 94, 766 (1961).
57. S. D. Robinson and B. L. Shaw, *J. Chem. Soc.* 4806 (1963).
58. F. J. Impastato and K. G. Ihrman, *J. Am. Chem. Soc.* 83, 3726 (1961).
59. R. A. Plowman and F. G. A. Stone, *Z. Naturforsch.* 17b, 575 (1962).
60. H. D. Murdoch and E. Weiss, *Helv. Chim. Acta* 45, 1927 (1962).
61. R. F. Heck and C. R. Ross, *J. Am. Chem. Soc.* 86, 2580 (1964).
62. W. T. Dent, R. Long and A. J. Wilkinson, *J. Chem. Soc.* 1585 (1964).
63. J. K. Nicholson, J. Powell and B. L. Shaw, *Chem. Comm.* 174 (1966).
64. R. Criegee and G. Schröder, *Ann.* 623, 1 (1959).
65. G. F. Emerson, K. Ehrlich, W. P. Giering and P. C. Lauterbur, *J. Am. Chem. Soc.* 88, 3172 (1966).
66. N. L. Bauld, *Tetrahedron Letters* 1841 (1963).
67. C. E. Coffey, *J. Am. Chem. Soc.* 83, 1623 (1961).
68. M. S. Kharasch, R. C. Seyler and F. R. Mayo, *J. Am. Chem. Soc.* 60, 882 (1938).
69. P. E. Slade and H. B. Jonassen, *J. Am. Chem. Soc.* 79, 1277 (1957).
70. R. B. King and F. G. A. Stone, *Inorg. Syntheses* 7, 193 (1963).
71. F. Ramirez, H. Yamanaka and O. H. Basedow, *J. Am. Chem. Soc.* 83, 173 (1961).
72. R. F. C. Brown and R. K. Solly, *Tetrahedron Letters* 169 (1966).

73. J. R. Case, R. Clarkson, E. R. H. Jones and M. C. Whiting, Proc. Chem. Soc. 150 (1959).
74. E. H. Braye, C. Hoogzand, W. Hubel, U. Krüerke, R. Merényi and E. Weiss, "Adv. in Chem. of Coord. Compounds" Ed. by S. Kirschner, Macmillan, New York P.190 (1961).
75. O. S. Mills and G. Robinson, Proc. Chem. Soc. 156 (1959).
76. H. W. Sternberg, J. G. Shukys, C. D. Donne, R. Markby, R. A. Friedel and I. Wender, J. Am. Chem. Soc. 81, 2339 (1959).
77. G. Albanesi and M. Tovaglieri, Chim. e. ind. 41, 189 (1959).
78. E. LeGoff, J. Org. Chem. 29, 2048 (1964).
79. J. Chatt, F. A. Hart and H. R. Watson, J. Chem. Soc. 2537 (1962).
80. W. F. Edgell and M. P. Dunkle, J. Phys. Chem. 68, 452 (1964).
81. P. M. Maitlis and M. L. Games, Can. J. Chem. 42, 183 (1964).
82. Beilstein, "Handbuch der organischen Chemie", 4th Ed. Vol. 19 (II 192).
83. J. C. Sauer, R. D. Cramer, V. A. Engelhardt, T. A. Ford, H. E. Holmquist and B. W. Howk, J. Am. Chem. Soc. 81, 3677 (1959).
84. M. I. Kabachnik, T. Y. Medved, Y. M. Polikanpov and K. S. Yudina, Izv. Akad. Nauk. S.S.S.R., Otd. Khim. Nauk. 1584 (1962).
85. P. T. Keough and M. Grayson, J. Org. Chem. 27, 1817 (1962).